

R290 Inverter Swimming Pool Heat Pump

TECHNICAL MANUAL



Applicable model:

PW010-KZXYP-E
PW020-KZXYP-E
PW030-KZXYP-E
PW040-KZXYP-E
PW050-KZXYP-E
PW060-KZXYP-E
PW070-KZXYP-E
PW080-KZXYP-E

**IMPORTANT SAFETY INSTRUCTIONS
READ AND FOLLOW ALL INSTRUCTIONS
SAVE THESE INSTRUCTIONS**

WARNING



WARNING

The refrigerant R290 (Propane) is flammable and it must be handled only by competent and responsible operators, under the conditions specified in the safety regulations in force.



R290



Before starting any operation read this manual and pay particular attention to Section "**Safe Handling of R290 Refrigerant**" providing information on flammable refrigerants.

Table of Contents

Safe Handling of R290 Refrigerants	1
1.Safety regulations	6
2.Working Principle	10
3.Specification	11
3.1 Dimension(Unit: mm)	11
3.2 Product data	12
3.3 Key Components	15
3.4 Exploded view	19
4.Installation	21
4.1 Installation diagram	21
4.2 Preparation and precautions before installation	22
4.3 Installation position	27
4.4 Installation details	28
4.5 Drainage and Condensation	30
4.6 Water system connection	31
4.7 Circulation water pump selection	36
4.8 Water pressure debugging	37
4.9 Pipe insulation requirements	37
5.Electrical Connections	38
5.1 Electrical Wiring Precautions	38
5.2 Electrical Wiring	38
5.3 Temperature Sensor Position	40
5.4 Electrical Wiring Diagram	41
6.Commissioning	46
6.1 Precautions	46
6.2 Trial Operation	46
7.Heat pump operation	47
7.1 Overview	47
7.2 Basic Model of System Control Chart	47
7.3 Wired Controller	47
7.4 Key Button	48
7.5 Parameter query and setting	49
7.6 Clock Setting	50
7.7 Timer power on/off settings	51
7.8 Smart Grid (SG-Ready)	52
7.9 Key Operation	53
7.10 Users' Guide	54
8. General Maintenance	56

8.1 Daily inspection of heat pump	57
8.2 Maintenance of Main Structural Components	57
8.3 Maintenance of Main Electrical Components	57
8.4 Maintenance of Main Water pipeline Components	58
8.5 Maintenance of anti-freeze	58
8.6 Refrigerant Charging	59
9. Error Code List and Trouble shooting	61
9.1 Main electronic control ports and functions	61
9.2 Controller Error Codes	63
9.3 Owner Inspection	65
9.4 Troubleshooting	65
10.WIFI Connection and Operation	97
10.1 APP Download	97
10.2 Registration&Login	97
11.3 WIFI network configuration steps	98
10.4 Functional Operation	100
10.5 Mode Settings	102
10.6 Timing Settings	102
10.7 Device Removal	103
10.8 Status parameters	104
10.9 Water temperature setting	104
Appendix	105
A. Commissioning Checklist	105
B.Temperature sensor resistance with different ambient temp.	107

Preface

The R290 Inverter air source swimming pool heat pump transfers heat from the ambient air to the water, it can operate stably and efficiently in extremely cold regions of -20°C, the operating hot water temp from 9~40°C, it's widely used in mid-range and high-range house swimming pools.

This ultra quiet series is newly designed and developed for customers in coastal countries or regions with new appearances, it avoids any corrosion in the harsh working conditions and is suitable for swimming pools from 15m³ to 130m³ under these conditions: Air 27°C, Water 26°C, Humidity 80%, indoor pool covered with an insulation cover.

Safe Handling of R290 Refrigerants

Please follow these safety instructions closely to prevent accidents

1. The heat pump unit contains flammable refrigerant and belongs to the A3 safety group according to ISO 817 and ANSI / ASHRAE Standard 34. Contains the flammable refrigerant R290 (propane C3H8). If a leak occurs, the escaping refrigerant may create a flammable or explosive atmosphere in the ambient air. Define a safe area around the outdoor unit with special requirements for equipment maintenance.

2. Hazard explosion risk:

The leaking refrigerant may create a flammable or explosive atmosphere in the ambient air. Take the following measures to prevent fire and explosion in the safe area:

2.1 Keep away from ignition source, such as naked flame, high temperature surface, electrical equipment without ignition source, and mobile devices with integrated batteries (such as mobile phones, health watches, etc.).

2.2 Allowed tools: All tools working in safe areas must meet the standards and regulations applicable to A2L and A3 safety group refrigerants, such as brushless machinery (wireless screwdriver), pumping equipment, waste containers, installation auxiliary tools, vacuum pump, conductive hose, mechanical tools made of non-spark generating materials, etc. Note that the tool must also apply to the range of pressure used. The tool must be in good condition.

2.3 The electrical equipment must meet the requirements of the explosion risk area.

2.4. Do not use flammable materials, such as sprays or other flammable gases.

2.5 Discharge static electricity: before starting work, safely touch grounded objects, such as ground wire or metal water pipe.

2.6 Do not remove, block, or bridge the safety equipment.

2.7 Prohibit to made any change of the heat pump inlet/outlet pipe, electrical connection or cable

2.8 No components or seals shall be removed.

3. Special Notes for installation and maintenance

 **WARNING** - Before installing this product, read and follow all warning notices and instructions which are included. Failure to follow safety warnings and instructions can result in severe injury, death, or property damage.

Codes and Standards

The Inverter Swimming Pool Heat Pump must be installed in accordance with the local building and installation codes as per the utility or authority having jurisdiction. All local codes take precedence over national codes. In the absence of local codes, refer to the latest edition of the National Electric Code (NEC) in the local government Electric Code (CEC) for installation.

DANGER — Risk of electrical shock or electrocution.



The electrical supply to this product must be installed by a licensed or certified electrician in accordance with the National Electrical Code and all applicable local codes and ordinances. Improper installation will create an electrical hazard which could result in death or serious injury to heat pump users, installers, or others due to electrical shock, and may also cause damage to property. Read and follow the specific instructions inside this guide.

 **WARNING** - To reduce the risk of injury, do not permit children to use this product unless they are closely supervised at all times.

It is necessary to power off both the indoor and outdoor units, especially a separate fuse or main isolating switch. Check that the system is no longer charged before maintenance.

Note: Besides the control circuits, there may also be some multiple power supply circuits.

3.1, R290 refrigerant (propane) is a colorless, tasteless, flammable gas, which forms an explosive mixture with air. During handling, air must be emptied and the discharged refrigerant is properly handled by an authorized contractor.

Implement the following measures before starting the refrigerant Circuit inspection work:

- Check the refrigerant circuit with any oil/gas leakage.
- Ensure adequate ventilation throughout the work period, especially in the floor area. Ensure that the air ventilation volume is enough or take out other ventilation measurement.
- Protect the surrounding area.
- Notify all maintenance personnel and other personnel nearby the heat pump.
- Check the area around the heat pump for flammable substances and ignition sources, and remove all flammable substances and ignition sources.
- Before, during, and after maintenance work, use R290 detector to check the surrounding area for any escaping refrigerant risk. Ensure that the refrigerant detector does not generate any sparks and must be properly sealed.

3.2 Carbon dioxide or powder fire extinguishers must be prepared in the following cases:

- The refrigerant is being discharged.

- The refrigerant is being added.
- During the welding work
- Display of no-smoking signs area.

WARNING: Touching component with electricity may cause serious damage. Some components may maintain electric charge even after the power is turned off. Make sure to wait at least 4 minutes to ensure that the voltage is fully dissipated before removing the Casing.

- Make sure the System is securely connected.
- Wear appropriate personal protective equipment for any work.

DANGER: burns or scald. Cold surfaces may cause frostbite.

- Turn off the equipment and let it cool or heat up before performing the maintenance service.
- Do not touch the hot or cold surfaces on the equipment, fittings, or pipes.

DANGER: Leaking refrigerant can cause fire and explosion and very serious injury or even death.

- Do not drill or heat the refrigerant circuit filled with refrigerant.
- Do not operate the air valve unless the filling valve or pumping equipment is connected.
- Take measures to prevent electrostatic touch.
- **NO SMOKING!** Prevent bare flames and sparks. Never turn ON/OFF of lighting or other electrical devices.
- Components containing or ever containing refrigerant must be indicated and stored and transported in well-ventilated areas in accordance with applicable regulations and standards.

DANGER:Direct exposure to liquids and gaseous refrigerants may cause serious health damage, such as frostbite and / or burns. If inhaled, it may a risk of suffocation.

- Prevent the direct contact with the liquid and gaseous refrigerants.
- Wear personal protective equipment when handling liquids and gaseous refrigerants.
- Do not inhale the refrigerant vapor.

DANGER:Refrigerant at high pressure: applying mechanical load on pipelines and components may cause leakage in the refrigeration circuit. Do not apply mechanical load on pipelines and components, such as by supporting or placing tools.

Hot and cold metal surfaces of the refrigeration circuit may cause burns or frostbite if the skin comes into contact with these surfaces. Wear personal protective equipment to prevent burns or frostbite. The hydraulic components may get freezed when removing the refrigerant.

4. These instructions shall apply only to qualified contractors:

- Work on a refrigeration circuit with a flammable refrigerant (safety group A3), shall be performed only by an authorized heating contractor. These heating contractors must be trained in accordance with EN 378 Part 4 or IEC 60335-2-40 Section HH and have competency certificates issued by industry recognized bodies.
- The brazing / welding of the refrigeration circuit shall be performed by qualified contractors per ISO 13585, AD 2000 and Data Sheet HP 100R certification. Only for contractors with the required process qualification and certification. All work must be performed within the scope of application and in accordance with the prescribed procedures. Welding / brazing work on the battery connection must comply with the pressure equipment directive (2014 / 68 / EU), with personnel and process certified by the notification agency.
- The work of the electrical equipment can only be carried out by the qualified electricians.

- Before the first operation, all safety-related key points must be inspected by a specifically certified heating contractor. The system must be operated by the system installer or a qualified person authorized by the installer.

4.1. Special Note of installation and maintenance work.

Please pay attention to the antifreeze protection

- Thermal insulation of all the hydraulic pipes.
- To activate the antifreeze function, connect the heat pump to the power supply before filling the secondary circuit. Turn on the power supply and open the switch on the indoor unit.
- Only an appropriate fill water conforming to VDI 2035 standards, rather than a medium containing antifreeze, is used to fill the secondary circuit.

Please note to replace accessories

- Repairing the safety function components may endanger the safe operation of the system, and spare parts and vulnerable parts not tested with the system may endanger their functions. The installation of unauthorized components and making unapproved modifications or transformations may endanger safety and may invalidate our warranty. When replacement, please use only the original spare parts provided or approved by the manufacturer.

4.2. Treatment method of refrigerant leakage

DANGER A refrigerant leak can cause fire and explosion and cause very serious injury or death. If inhaled, there is a risk of suffocation.

- Make sure that the ground area of the outdoor unit is very well ventilated.
- **NO SMOKING!** Prevent bare fires and sparks. Never turn on or off the lights or electrical equipment.
- Evacuate the personnel from the dangerous area.
- Cut off the power supply to all the system components from a safe position.
- Remove the ignition source from the dangerous area.
- Notify user don not to introduce the ignition source into the danger area during the maintenance period.
- Maintenance work must be carried out by an authorized contractor.
- The system can only be restarted after the system repair is completed.
- Prevent direct contact with liquid and gas refrigerants.
- Do not inhale the refrigerant vapor.

DANGER Direct exposure to liquids and gas refrigerants can cause serious harm to health, such as frostbite and / or burns. Inhalation may cause a risk of suffocation.

4.3. When water leakage occurs in the heat pump

DANGER: There is a risk of electric shock if the water leaks from the equipment. Turn off the external isolators of the heating system (e. g., box, home distribution box).

DANGER: There is a risk of scald if the equipment leaks water. Do not touch the hot water.

If the heat pump get frozen, take the following measures:

Note that freezing in the fan area of the condensing disk and the outdoor unit may cause damage to the equipment. Note the following items:

- Do not use mechanical items / tools to de-ice.
- Before using the electric heating equipment, check the refrigerant circuit for leakage using the appropriate

measuring equipment.

- The electric heating equipment shall not be an ignition source.
- The electric heating equipment must meet the requirements of EN 60335-2-30.
- If the heat pump often get frozen (such as in areas where frost and fog often occur), install fan ring heating (accessories) for refrigerant R290 and / or electric belt heater (accessories or factory configuration) on the condensing plate.

4.4 Safety Guide for storage of heat pump

The heat pump has been filled with refrigerant R290 (propane) in the factory.

DANGER: Leaking refrigerant can cause fire and explosion, causing very serious injury and even death. If inhaled, there is a risk of suffocation.

Store the heat pump under the following conditions:

- The storage site must have an explosion-proof plan.
- Ensure that the storage site is adequately ventilated.
- Temperature range for storage: -25°C to 70°C.
- Only store the heat pump with factory protective packaging.
- Protect the heat pump from damage.
- The maximum number of heat pumps that can be stored in one location is determined by local conditions

4.5. The below regulations shall be followed:

- National installation regulations.
- Accident prevention regulations.
- Environmental protection laws and regulations.
- Pressure equipment regulatory requirements: Pressure Equipment Directive 2014 / 68 / EU.
- Practice regulation from relevant industry associations.
- Relevant country-specific security regulations.
- Applicable regulations and guidelines for the operation, service, maintenance, repair and safety of refrigeration, air conditioning and heat pump systems containing flammable and explosive refrigerants.

1.Safety regulations

Before installing this product, please read and follow all warnings and installation instructions. Failure to follow safety warnings and installation instructions may result in serious injury, death, or property damage.

The following symbols are very important. Please make sure to understand their meaning, as it involves the product and your personal safety.

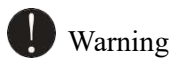











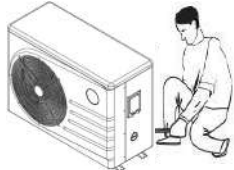

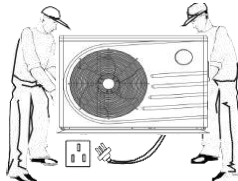



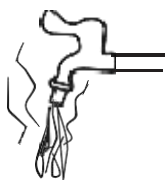

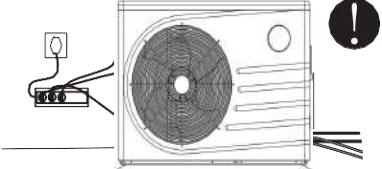

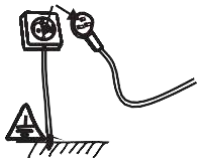
Warning



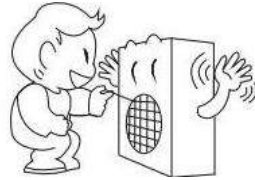

Precaution

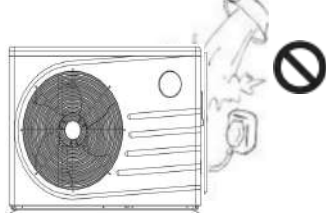

Prohibition

 	 	 
<p>The installation, disassembly and maintenance of the unit must be carried out by professional after-sales personnel. No changes to the structure of the unit, which may cause damage to the unit and personal injury.</p>	<p>To avoid electric shock, please be prepared. When repairing electrical components, be sure to disconnect the power supply for at least 1 minute. Even after 1 minute, use a multi-meter to measure the voltage at the main power terminal. Before touching capacitors or electrical components, ensure that the voltage is lower than the safety voltage for the human body.</p>	<p>Please be sure to read this manual first to use it.</p>
 	 	 
<p>To obtain clean hot water, be sure to add a mixing valve in front of the faucet and set it to the appropriate temperature.</p>	<p>Please use a dedicated socket, otherwise malfunction may occur.</p>	<p>The power supply provided to the unit must be grounded.</p>
 	<p>This device is suitable for children and adults aged 8 years and above, and other personnel need to use it under the supervision of a fully capable guardian. Children are not allowed to play with this device, and children are not allowed to clean and maintain this device.</p>	
 	 	 

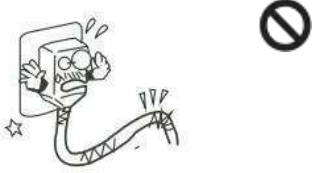
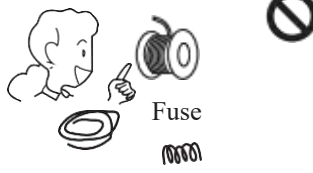
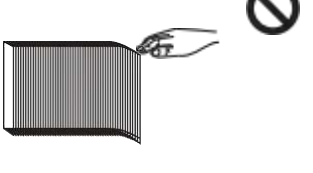
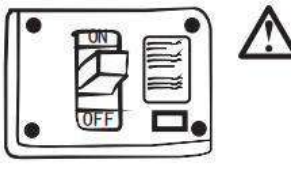
Do not touch the air outlet grille when the fan motor is running.	Do not touch the power plug with wet hands.	It is strictly prohibited to pour water or any liquid into the product, as it may cause leakage or malfunction of the product.
---	---	--

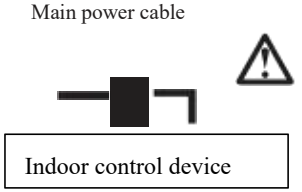
		
When the power cord is loose or damaged, please seek professional after-sales personnel for repair.	Please choose the correct fuse or circuit breaker according to the suggestions. Steel wire or copper wire cannot be used as a substitute for fuses or circuit breakers. Otherwise, it may cause damage.	Be careful not to touch the fins with your fingers, otherwise you may be cut by the fins.
		
Please select the appropriate specification of circuit breaker based on the rated current of the product.	Disposal of waste batteries (if any). Please dispose of according to local garbage classification standards.	It is recommended to install a residual current protection device (RCD) with a rated residual operating current not exceeding 30mA.
<ol style="list-style-type: none"> 1. It is recommended to fill this system with pure water. 2. If using urban water for filling, please soften the water and add a filter. 3. Note: After filling, the water supply system should be 0.15~0.6MPa 		

Transport, storage and handling warning

1. The heat pump must be transported, handled and stored vertically. Tipping the machine may cause the compressor or other components damage.

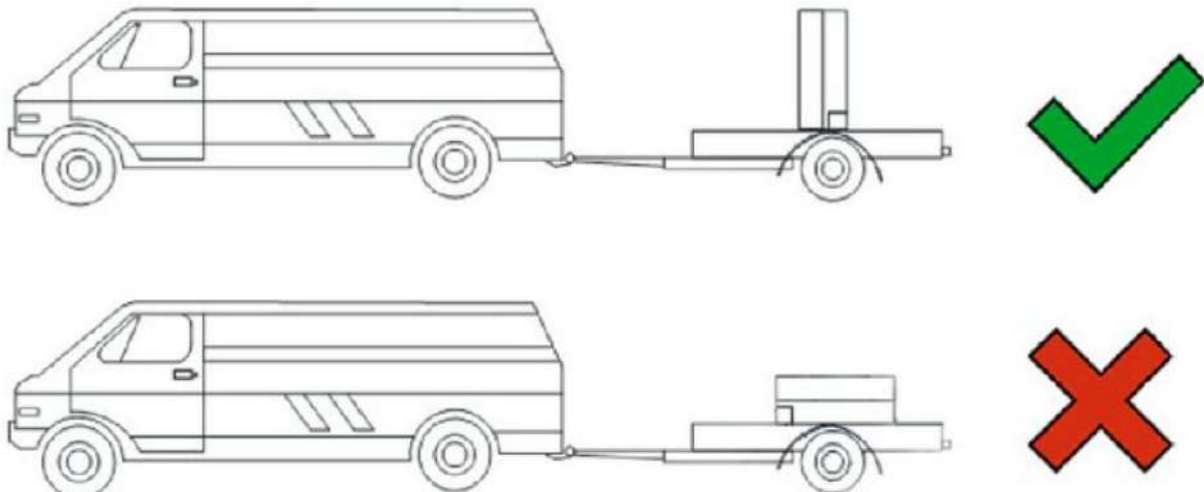

2. Do not twist, loosen or pull the external electric cables of the heat pump. Do not insert any sharp objects through the fan grille or into the fan itself.
3. Do not wash the interior of the heat pump with water as this may result in electric shock or fire. For any cleaning and /or maintenance operations, disconnect the main power supply.

Unit recycling and scrapping warning

This label indicates that the product should not be disposed of together with other household waste throughout the EU region. To prevent the potential harm of uncontrolled waste disposal to the environment or human health, material resources should be responsibly recycled and utilized. To return the device you have used, please use a recycling and collection system or contact the retailer who purchased the product. They can use this product for environmentally friendly and safe recycling.

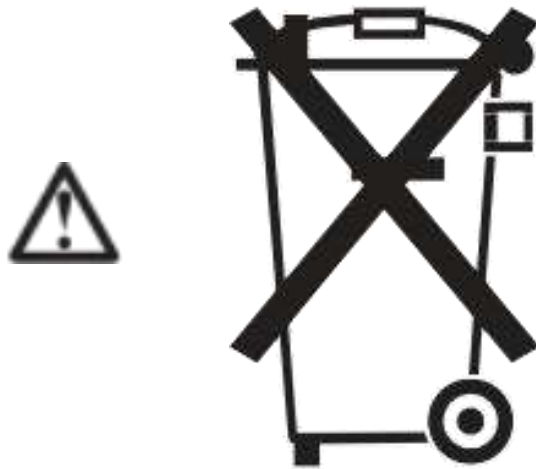

! WARNING

1. Users are not recommended to install this device on their own. They must entrust an agent or a professional installation company authorized by our company to install it, otherwise it may cause safety accidents and affect the effectiveness of use.
2. Except for the guidance of professional personnel, non professional personnel are not allowed to dismantle the unit without authorization, otherwise accidents or damage to the unit may occur.
3. Do not use or store flammable items such as hair spray, paint, gasoline, alcohol, etc. near this machine, as this may cause a fire.
4. The main power switch of the unit should be placed out of reach of children to prevent safety hazards caused by children's contact with the power switch.
5. In thunderstorm weather, please cut off the main power switch of the unit, otherwise it may cause danger or damage to the unit.
6. The unit should use an independent power switch to avoid sharing the same circuit with other electrical appliances; And select a power line that matches the current and a circuit breaker (with leakage protection function) to supply power to the unit.
7. The unit must install a grounding wire with a specified cross-section. Do not connect the grounding wire to the grounding wire of gas pipelines, water pipes, lightning protection wires, or telephones. At the same time, it must be reliably grounded to avoid accidents.
8. Do not forcefully cut off the power supply during unit operation to avoid accidents.

9. When the unit is not in use for a long time, please drain the water in the pipeline and close the water pipe valve; And disconnect the main power switch to avoid accidents.

10. The unit should use a dedicated power supply, and the power supply voltage should comply with the rated voltage standard

11. When the power cord is damaged, the power cord specified by the manufacturer must be used and replaced by professional maintenance personnel.

PRECAUTION

1. Do not put your hands or foreign objects into the air outlet, as high-speed fans may endanger personal safety.

2. Do not remove the air guide net cover of the unit, otherwise the high-speed running fan may cause injury to personnel.

3. Lightning and other electromagnetic radiation sources may affect this device. If this situation occurs, please cut off the power and then power on again.

4. When using, ensure that the air in the pipeline is completely discharged, and then open the makeup valve to refill the system with water.

Before operating the machine, please carefully read all "warnings" and "precautions".

6. The "Warning" and "Precautions" list various important safety related matters, please strictly follow them.

7. The working environment of the unit should be kept away from fire sources. If a fire is caused by wiring issues, the main switch should be immediately turned off and a dry powder fire extinguisher should be used to extinguish the fire.

8. Before repairing the unit, the power must be cut off.

9. It is prohibited to place objects above the unit to avoid accidents caused by falling objects during unit operation.

WARNING:

1. Do not use means to accelerate the defrosting process or to clean, Other than those recommended by the manufacturer.

2. The appliance shall be stored in a room without continuously operating ignition sources (for example: open flames, an operating gas appliance or an operating electric heater.)

3. Do not pierce or burn.

4. Be aware that refrigerants may not contain an odour.

WARNING: Please empty the water in heat pump always during winter time or when the ambient temperature drops below 0°C if the power supply is cut off, or else the Titanium exchanger will be damaged because of being frozen, in such case, your warranty will be lost.

WARNING: Please always cut the power supply if you want to open the cabinet to reach inside the heat pump, because there is high voltage electricity inside.

WARNING: Please keep the display controller in a dry area, or close the insulation cover to protect the display controller from being damaged by humidity

2. Working Principle

The heat pump system mainly consists of four components: **compressor**, **condenser**, **throttling device(EEV)**, and **evaporator**. Its working principle is to use electric energy to drive the compressor to work, compressing low-temperature and low-pressure gas refrigerant into high-temperature and high-pressure steam, and then condensing and dissipating heat in the condenser (titanium tube heat exchanger), releasing heat to the heat transfer medium (water), and providing a heat source to the pool through the heat transfer medium (water); After condensation, the medium temperature and high pressure refrigerant is throttled by a throttling device(EEV) and turns into a low-temperature and low-pressure liquid. Then, it absorbs heat from the air environment through an evaporator (finned heat exchanger), and then the refrigerant vaporizes forming a low-temperature and low-pressure gas that enters the compressor again for compression, forming a repeated circulation.

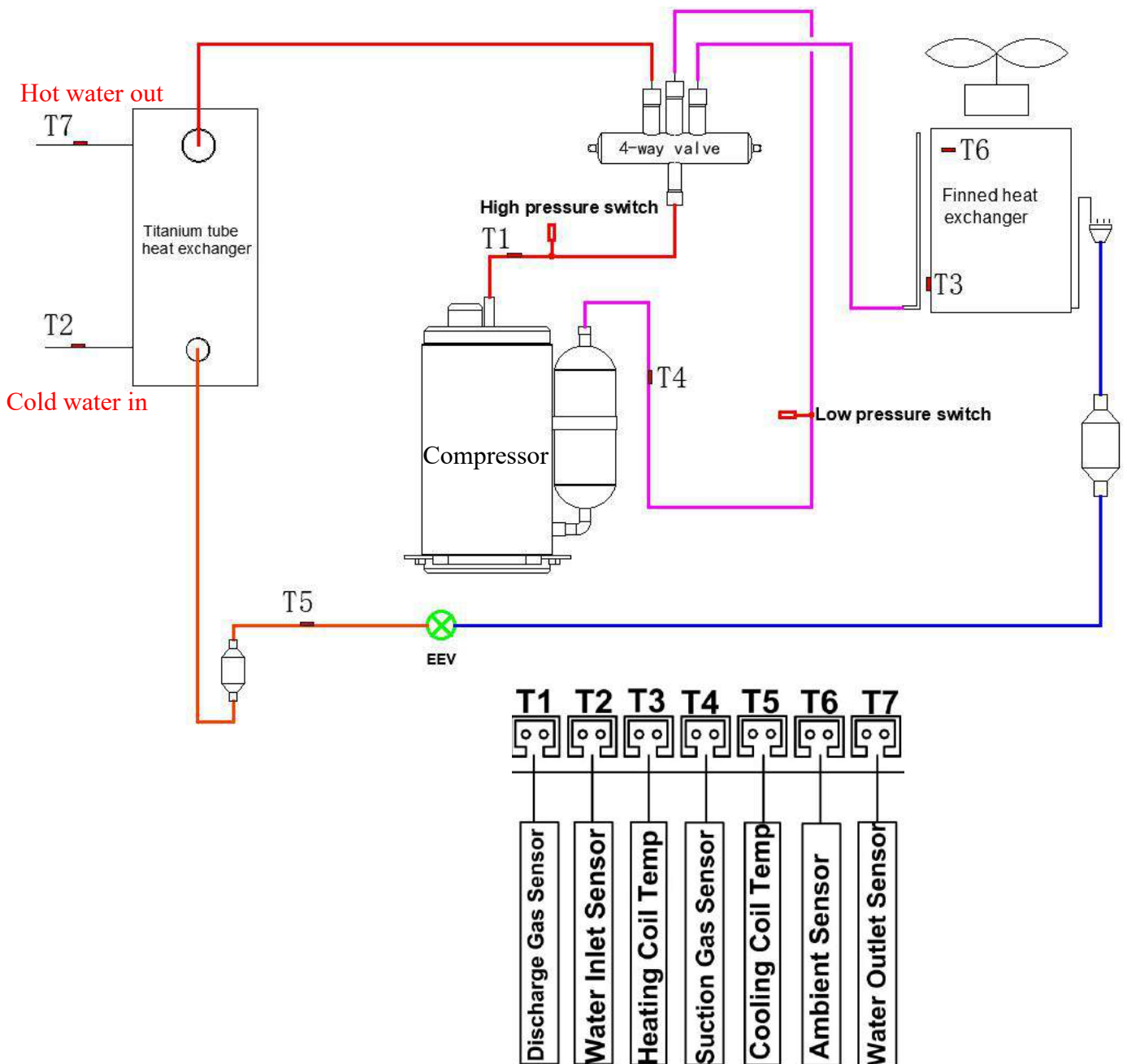

3.Specification

3.1 Dimension(Unit: mm)

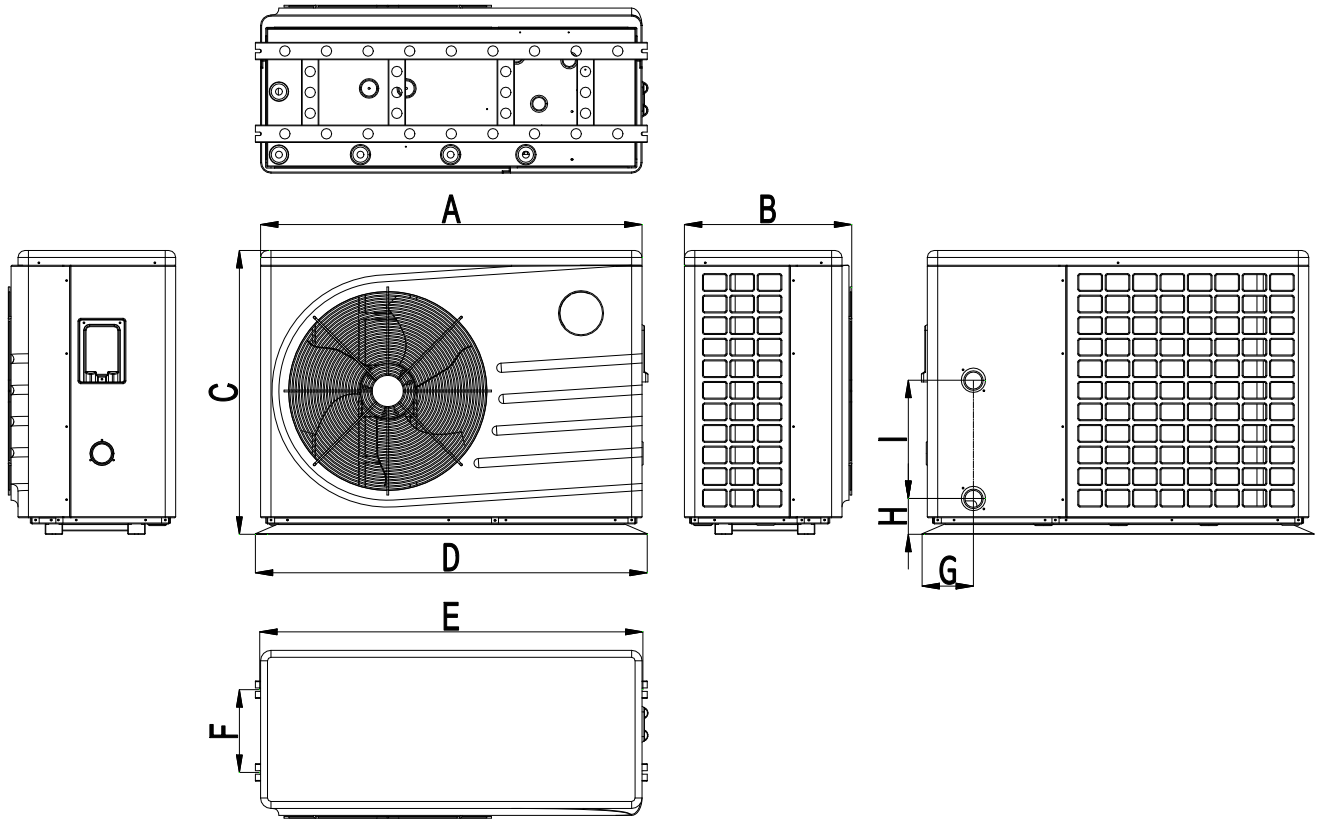

Model	A	B	C	D	E	F	G	H	I
PW010-KZXCYC-E	1006	410	605	1036	1021	180	141	102	250
PW020-KZXCYC-E	1006	410	605	1036	1021	180	147	102	300
PW030-KZXCYC-E	1006	410	605	1036	1021	180	147	102	300
PW040-KZXCYC-E	1100	480	816	1130	1105	238	148	102	340
PW050-KZXCYC-E	1100	480	816	1130	1105	238	148	102	400
PW060-KZXCYC-E	1100	480	816	1130	1105	238	148	102	470
PW070-KZXCYC-E	1211	490	980	1235	1220	240	147	102	420
PW080-KZXCYC-E	1211	490	980	1235	1220	240	147	102	470

3.2 Product data

Model	PW010-KZXYS-E	PW020-KZXYS-E	PW030-KZXYS-E	PW040-KZXYS-E
Operating air temperature (°C)	-20 ~43			
Performance Condition: Air 27°C, Water 26°C, Humidity 80%				
Heating capacity (kW)	6.0~1.6	9.0~2.2	12.0~3.0	16.0~3.5
Heating Capacity(Btu)	20470~5460	30700~6820	40940~10240	54590~11940
Consumed power (kW)	0.90~0.09	1.32~0.12	1.76~0.16	2.32~0.19
COP	6.7~18.5	6.8~18.4	6.8~18.6	6.9~18.7
COP at 50% capacity	10.2	10.1	10.3	10.4
Performance Condition: Air 15°C, Water 26°C, Humidity 70%				
Heating capacity (kW)	4.6~1.3	7.0~1.7	9.0~2.2	11.8~2.7
Heating Capacity(Btu)	15700~4435	23880~5800	30700~7500	40260~9210
Consumed power (kW)	1.17~0.20	1.51~0.24	2.05~0.29	2.62~0.37
COP	3.9~6.2	4.6~7.0	4.4~7.5	4.5~7.3
COP at 50% capacity	5.5	5.8	5.6	6.5
Performance Condition: Air 35 °C , Water 28 °C , Humidity 80%				
Cooling capacity (kW)	4.0	6.0	8.0	10.0
Consumed power (kW)	1.05	1.58	2.35	2.63
EER	3.8	3.8	3.4	3.8
Sound pressure at 1m dB(A)	36~48	38~49	40~50	43~53
Sound pressure of 50% capacity at 1m dB(A)	42	42	45	46
Sound pressure at 10m dB(A)	18~28	19~29	20~30	23~31
Heat exchanger	Spiral titanium tube in PVC			
Casing	ABS plastic casing black color			
Power supply	230V/1 Ph/50Hz/60Hz			
Water Connection (mm)	Φ50			
Max. power input(kW)	1.5	2.3	2.9	3.5
Max. current (A)	7.2	11.1	14.0	16.0
Advised water flux (m³/h)	2.6	3.9	5.2	6.9
Water Pressure Drop (max) kPa	2	5	9	9
Net weight/Gross weight(kg)	52/62	60/70	62/72	80/92
Body size(mm)	1036*410*605			1130*480*816
Refrigerant	R290/280g	R290/380g	R290/460g	R290/750g
Compressor	HIGHLY			
Four-way valve	Sanhua			
Expansion valve	Sanhua			
Operating water temperature (°C) *heating	9 ~40			
Operating water temperature (°C) *cooling	9 ~35			

Model	PW050-KZXCYC-E	PW060-KZXCYC-E	PW070-KZXCYC-E	PW080-KZXCYC-E
Operating air temperature (°C)	-20 ~43			
Performance Condition: Air 27°C, Water 26°C, Humidity 80%				
Heating capacity (kW)	20.0~4.0	24.2~5.3	28.6~8.3	33.1~8.5
Heating Capacity(Btu)	68240~13650	82570~18080	97583~28320	112937~27296
Consumed power (kW)	2.86~0.21	3.51~0.28	4.21~0.45	4.93~0.46
COP	7.0~18.8	6.9~18.7	6.8~18.6	6.7~18.5
COP at 50% capacity	10.3	10.1	10.2	10.1
Performance Condition: Air 15°C, Water 26°C, Humidity 70%				
Heating capacity (kW)	15~3.0	18.0~3.8	22.8~5.5	25.2~7.5
Heating Capacity(Btu)	51180~10230	61412~12960	77794~18766	85982~25590
Consumed power (kW)	3.33~0.44	4.0~0.52	4.91~0.81	5.36~1.15
COP	4.5~6.8	4.5~7.3	4.6~6.8	4.7~6.5
COP at 50% capacity	6.1	6.4	6.1	6.2
Performance Condition: Air 35 °C , Water 28 °C , Humidity 80%				
Cooling capacity (kW)	11.3	13.0	16.0	17.5
Consumed power (kW)	2.97	3.47	3.48	4.06
EER	3.8	3.8	4.60	4.3
Sound pressure at 1m dB(A)	43~54	44~56	47~58	48~60
Sound pressure of 50% capacity at 1m dB(A)	48	49	52	54
Sound pressure at 10m dB(A)	24~32	25~33	27~38	28~40
Heat exchanger	Spiral titanium tube in PVC			
Casing	ABS plastic casing black color			
Power supply	230V/1 Ph/50Hz/60Hz			
Water Connection (mm)	Φ50			
Max. power input(kW)	4.4	5.5	6.9	7.0
Max. current (A)	20.2	25.2	31.1	31.8
Advised water flux (m³/h)	8.6	10.1	12.04	14.2
Water Pressure Drop (max) kPa	14	19	20	20
Net weight/Gross weight(kg)	83/95	86/98	118/132	120/134
Body size(mm)	1130*480*816		1235*490*980	
Refrigerant	R290/850g	R290/1000g	R290/1500g	R290/1500g
Compressor	HIGHLY			
Four-way valve	Sanhua			
Expansion valve	Sanhua			
Operating water temperature (°C) *heating	9 ~40			
Operating water temperature (°C) *cooling	9 ~35			

Model	PW060-KZXCYC-E	PW070-KZXCYC-E	PW080-KZXCYC-E
Operating air temperature (°C)	-20 ~43		

Performance Condition: Air 27°C, Water 26°C, Humidity 80%			
Heating capacity (kW)	24.2~5.3	28.6~8.3	33.1~8.5
Heating Capacity(Btu)	82570~18080	97583~28320	112937~27296
Consumed power (kW)	3.51~0.28	4.21~0.45	4.93~0.46
COP	6.9~18.7	6.8~18.6	6.7~18.5
COP at 50% capacity	10.1	10.2	10.1
Performance Condition: Air 15°C, Water 26°C, Humidity 70%			
Heating capacity (kW)	18.0~3.8	22.8~5.5	25.2~7.5
Heating Capacity(Btu)	61412~12960	77794~18766	85982~25590
Consumed power (kW)	4.0~0.52	4.91~0.81	5.36~1.15
COP	4.5~7.3	4.6~6.8	4.7~6.5
COP at 50% capacity	6.4	6.1	6.2
Performance Condition: Air 35 °C , Water 28 °C , Humidity 80%			
Cooling capacity (kW)	13.0	16.0	17.5
Consumed power (kW)	3.47	3.48	4.06
EER	3.8	4.60	4.3
Sound pressure at 1m dB(A)	44~56	47~58	48~60
Sound pressure of 50% capacity at 1m dB(A)	49	52	54
Sound pressure at 10m dB(A)	25~33	27~38	28~40
Heat exchanger	Spiral titanium tube in PVC		
Casing	ABS plastic casing black color		
Power supply	380V/3Ph/50Hz/60Hz		
Water Connection (mm)	Φ50		
Max. power input(kW)	5.5	6.9	7
Max. current (A)	9.8	12.3	12.5
Advised water flux (m³/h)	10.1	12.04	14.2
Water Pressure Drop (max) kPa	19	20	20
Net weight/Gross weight(kg)	86/98	118/132	120/134
Body size(mm)	1130*480*816	1235*490*980	
Refrigerant	R290/1000g	R290/1500g	R290/1500g
Compressor	HIGHLY		
Four-way valve	Sanhua		
Expansion valve	Sanhua		
Operating water temperature (°C) *heating	9 ~40		
Operating water temperature (°C) *cooling	9 ~35		





Note:







The above design and specifications are subject to change without prior notice for product improvement.

Detailed specifications of the units please refer to nameplate on the units.

3.3 Key Components



The following are the main parts standard with the heat pump from factory.

Item	Picture	Name	Function
1		DC inverter compressor	The compressor is the heart component of the heat pump system. It is a "steam pump", which presses the low temperature and low pressure steam with high temperature and high pressure steam to provide the refrigerant in the heat pump system cycle
2		Titanium tube heat exchanger	It's used to condense the high-temperature and high-pressure refrigerant vapor from the compressor into a super-cooled liquid. During the condensation process, the refrigerant vapor releases heat, so it needs to be cooled with water or air. It's composed of titanium tube and PVC plastic casing or stainless steel casing. It has strong corrosion resistance, can resist the erosion of chloride ions in water, and has high heat exchange efficiency.
3		Finned type heat exchange	The fin-type heat exchange can be used as a condenser and as an evaporator. Heating for the evaporator, the low temperature and low pressure liquid refrigerant evaporation into a gas, to absorb the heat in the air. For refrigeration condenser, the high temperature and high pressure gaseous refrigerant is condensed into a liquid of medium temperature and high pressure, and the heat is distributed into the air.
4		Electronic expansion valve	A throttling and depressurizing device that throttles medium temperature and high pressure liquid refrigerant into low temperature and low pressure liquid refrigerant.)
5		Four-way switching valve	Allow the refrigeration system to freely switch between cooling and heating modes. During heating mode, and unit shutdown, the four-way valve is closed; During cooling mode and defrost mode, the four-way valve is energized

6		Water flow switch	When the waterway of the heat pump system is cut off or the flow rate is low, the water flow switch is disconnected and the heat pump unit stops working.
7		Red high pressure switch	High pressure switch: When the exhaust pressure of the heat pump system is higher than the protection value of the high pressure switch, the high pressure switch is disconnected and forces the unit to stop working to avoid damage to the unit.
8		Black low pressure switch	Low pressure switch: When the suction pressure of the heat pump system is lower than the protection value of the low pressure switch, the low pressure switch is disconnected and forces the unit to stop working to avoid damage to the unit.
9		Outdoor fan (DC motor + wind blade)	<p>It's composed of DC motor and fan blade; it can accelerate the blowing of air through the evaporator surface from the outside to improve the heat transfer efficiency and heat dissipation performance of the evaporator. It's controlled by the mainboard and wired controller.</p> <p>The outdoor fan provides strong air convection in the fin heat exchange to enhance the heat transfer exchange effect.</p>
10		Control panel	<p>accessories along with the machine, connect the circuit board for communication use to operate the machine).</p> <p>Set different water temp, operation mode, time setting, parameter query, control main parts, set address and so on.</p>
11		Communication wire(Four-core)	Accessories along with the machine, extension line connecting the circuit board and display; four-core communication line

12		R290 refrigerant leakage sensor *1(Standard)	<p>The refrigerant leakage sensor is used to detect and monitor the leakage of R290 refrigerant, ensuring the safety and efficiency of the system. When the leakage concentration exceeds 15% LFL, the system will sound an alarm and display fault code 209, reminding users to handle it in a timely manner to ensure safe use.</p> <p>The compressor and all electric heating will stop, and the fan is running at the lowest speed.</p>
13		Shock absorber pad (accessory)	It is used to cooperate with the installation of the heat pump base, fixed on the base, to reduce the vibration and noise of the unit operation
14		Water pipe connections and drainage accessories (accessory)	<p>The blue one is a PVC plastic joint that connects the inlet and outlet pipes of the unit;</p> <p>The black one is a pipe shaped drainage joint, installed on the bottom drainage hole of the unit;</p> <p>The white one is the condensate drain pipe, connected to the black drain joint.</p>

The following parts are key parts often used in the installation, customers need to purchase locally in advance.

No	Picture	Name	Function
1		Exhaust valve	Automatically drain air from the water system; or manually open the top cap to remove the air-liquid mixed water faster; prevent air inside the pipe.
2		Safety valve	When the pressure of the water system exceeds the design value of the safety valve, the safety valve automatically opens to release pressure, controlling the pressure of the water system to not exceed the specified design value, which plays an important protective role in personal safety and equipment operation.
3		Circulation water pump	The circulating water pump provides power for the transportation of heat transfer medium (water) in the heat pump water system, and then passes through the heat transfer medium (water). Remove the heat from the water side heat exchanger and

			increase or decrease the temperature of the heat transfer medium (water).
4		Check valve	Install a check valve on the water outlet connection in order to prevent back siphoning when water pump stops.
5		Chlorinator	The chlorinator can stably release chlorine solution into the swimming pool to achieve disinfection and sterilization purposes. It can also adjust the pH value of the swimming pool water to maintain water quality balance.
6		Ozone generator	The ozone generator in the swimming pool can quickly convert oxygen in the air into ozone, and through efficient oxidation reactions, eliminate pollutants such as organic matter, bacteria, viruses, etc., maintaining clean and transparent water quality. Ozone does not produce harmful by-products during the disinfection process and does not cause harm to the human body.
7		High speed filtering sand cylinder	It can further remove pollutants that have already coagulated in water, and achieve the goal of water purification through the interception, sedimentation, and adsorption of filter materials.
8		Ball valve	Install ball valves on the heat pump water inlet and outlet pipelines to control the flow of water.
9		Water pressure gauge	Installed on the inlet pipeline of the heat pump, detecting the water pressure status.

10		Thermometer	Installed on the inlet pipeline of the heat pump, detecting the water temperature status.
----	---	-------------	---

3.4 Exploded view

PW010/020/030/040/050/060/070/080-KZXYC-E

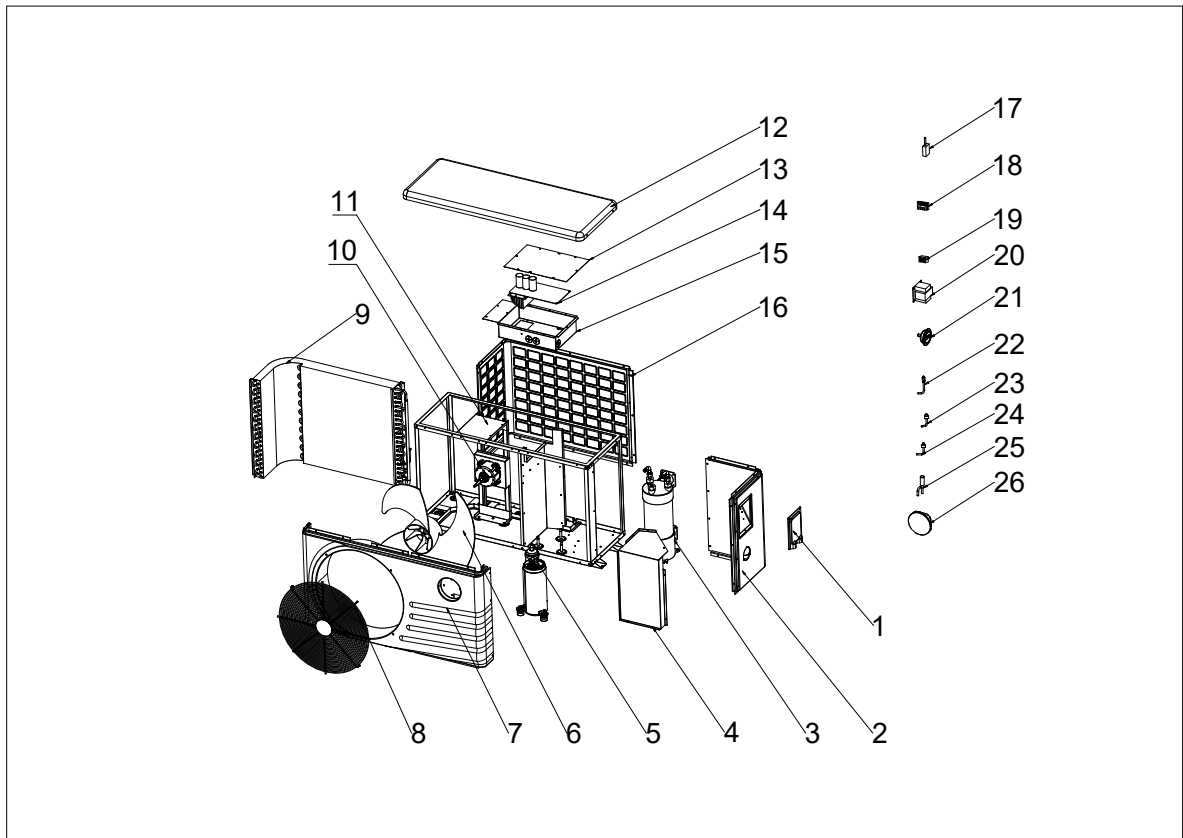

N0	Spare parts	N0	Spare parts
1	terminal block cover	16	behind panel
2	right side panel	17	R290 refrigerant leakage sensor
3	titanium foam	18	terminal block
4	noise suppressor cover	19	terminal block
5	compressor	20	electric reactor
6	fan blade	21	pressure gauge
7	front panel	22	needle valve
8	fan protection net	23	high pressure switch
9	finned heat-exchanger	24	low pressure switch
10	motor	25	electronic expansion valve
11	motor bracket	26	wired controller
12	top cover	27	needle valve
13	electric box cover		
14	driver board		
15	electric box		

4. Installation

4.1 Installation diagram

1. The heat pump must be protected from back-siphoning of water. If there is any chance of back-siphoning, provide a check valve(no.1) between the swimming pool and the heat pump outlet. The pool system components are Heat pump, Check Valve, Disinfection system, Filter and Water Pump.

2. Note: If automatic dosing equipment for chlorine and acidity (pH) is used(no.2), it is essential to protect the heat pump against excessively high chemical concentrations which may corrode the heat exchanger. For this reason, equipment of this sort must always be fitted in the piping on the downstream side of the heat pump, and it is recommended to install a check-valve(no.3) to prevent reverse flow in the absence of water circulation.

Note: Damage to the heat pump caused by failure to observe this instruction is not covered by the warranty.

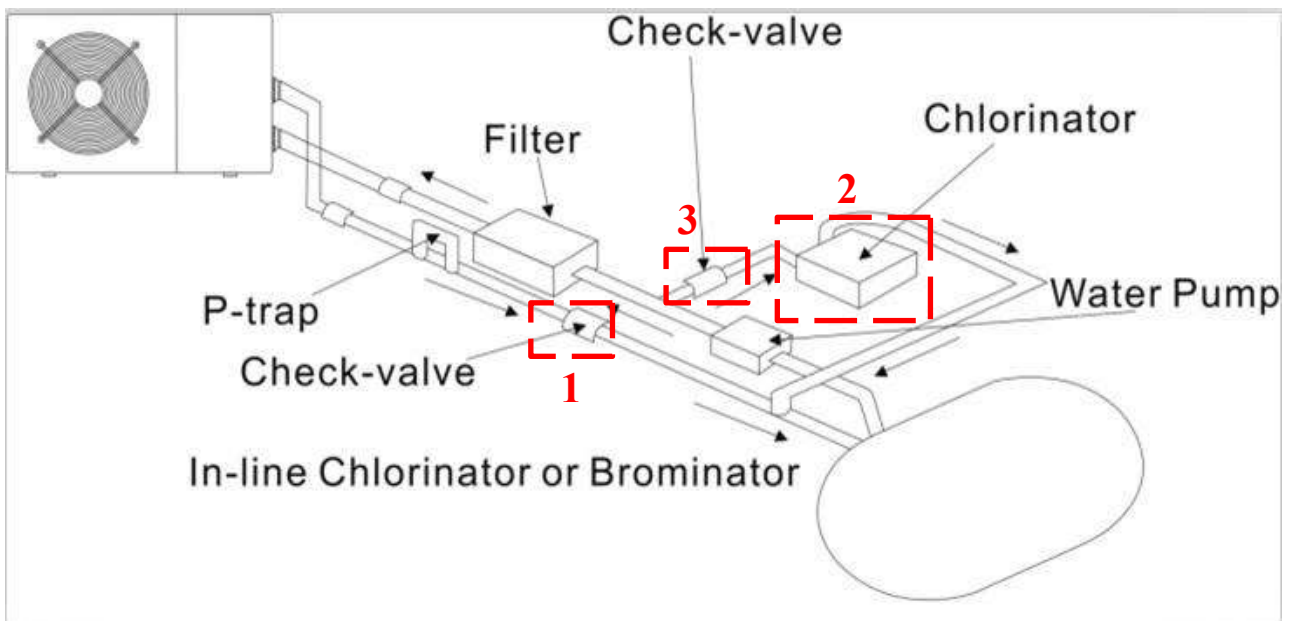

3. If the water flow rate of the pump is more than 20% greater than the allowable flow rate through the heat pump heat exchanger, install a bypass pipeline. (Purple box).

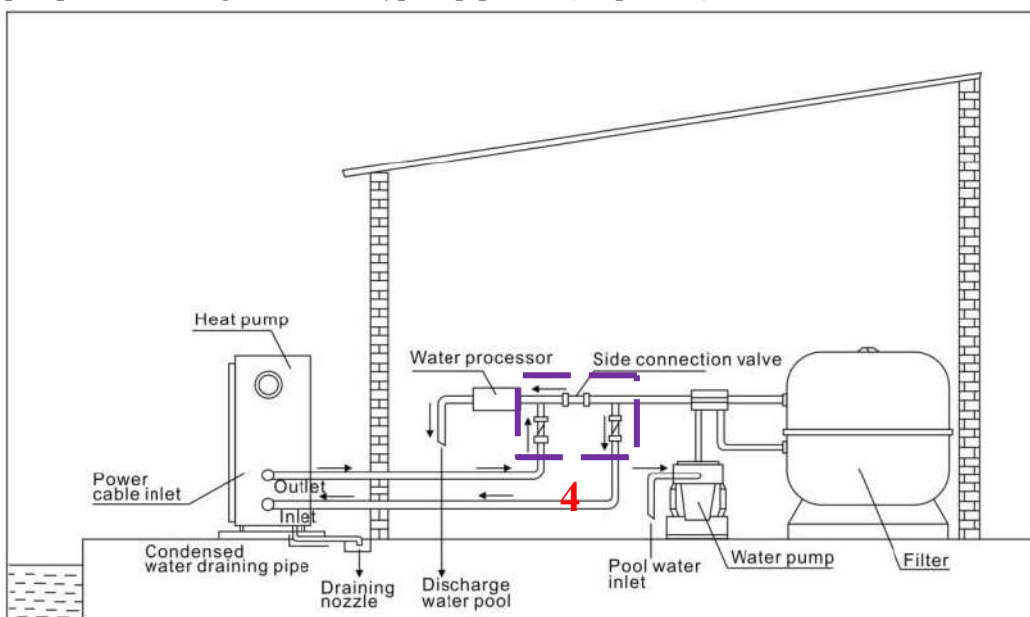

Note: The factory only supplies the heat pump. All other components, including a bypass if necessary, must be provided by the user or the installer.

Attention:

- (1) Please observe the following rules when installing the heat pump:
- (2) Any addition of chemicals must take place in the piping located downstream from the heat pump.
- (3) Install a bypass if the water flow from the swimming pool pump is more than 20% greater than the allowable flow through the heat exchanger of the heat pump.
- (4) Install the heat pump above the water level of the swimming pool.
- (5) Always place the heat pump on a solid foundation and use the included rubber mounts to avoid vibration and noise.
- (6) Always hold the heat pump upright. If the unit has been held at an angle, wait at least 24 hours before starting the heat pump.

4.2 Preparation and precautions before installation

4.2.1 Installation instructions and special precautions

- A. The heat pump heating and hot water system should be a closed-loop system, if using antifreeze liquid or other liquid, please consult to Manufacture;
- B. Filter must be installed before the water inlet pipe of the heat pump, and the number of filter mesh is above 40;
- C. The filter mesh in the filter must be made of stainless steel to avoid scratches on the system caused by impurities in the filter.

The heat pump uses the non-toxic micro-combustion refrigerant R290:

- 1) Lower limit of ignition [LFL% (V / V)]: 2.1 vol%; 0.038 kg / m³
- 2) Automatic ignition temperature, refrigerant ignition point AIT: 470°C
- 3) Minimum ignition energy MIE: 0.31 mJ
- 4) Combustion speed BV: 46 cm / s
- 5) Combustion heat HOC: 50.3 MJ / kg
- 6) Occupational contact limit OEL: 1000 PPMv
- 7) Safety level (ASHRA34): A3

Confirm the critical concentration and take necessary measures by following the steps below

Calculate total refrigerant volume (A [M load 3]) 22 refrigerant volume + additional addition.

. Calculate the indoor volume (B [m³]) (as the minimum volume)

. Calculate the refrigerant concentration. Prevent excessive concentrations. $[A / (A+B)] < 14.4\%$

. Install a ventilator to reduce the refrigerant concentration to a critical level.

. If long-term ventilation is impossible, please install a leakage alarm device associated with the ventilator.

5.2.2 Disclaimer instruction

1. The product shall be supplied independently by copper core power wire that meets the required wire diameter, and the unit shall have reliable grounding wire; if the wiring does not meet the requirements, the company shall not be responsible accordingly.

2. When cleaning the unit, cut off the power switch. If the unit is cleaned under electric operation, resulting in electric shock and personal safety injury, the company shall not be responsible for this.

3. In winter or when the ambient temperature is below 2°C, if the water is not used for a long time, please be sure to empty the water in the waterway and the water tank to prevent the water from freezing and expanding, which results in freezing of the water pipe and the water tank, damaging the unit. If the unit stops the anti-freezing protection due to the power failure, the company shall not be responsible for it.

WARNING

1. Before installation, it shall be confirmed that the voltage of the power grid is consistent with the required voltage of the unit, and whether the open load capacity of the wires and sockets meets the maximum power requirements.

2. If the standing appliance is not equipped with power cord and plug, and there is no other device that disconnected the power supply (the contact distance is fully disconnected under the overvoltage level), the fixed wiring must be connected with the full pole disconnected leakage protection device with the contact distance greater than 3mm according to the wiring rules.

3. Please entrust the dealer or professional personnel to install; the DIY installation shall have relevant professional knowledge, otherwise may cause water leakage, fire, electric shock, or injury.

4. The auxiliary products purchased locally must use the products designated by the company;

5. Please follow the regulations of the local electrical company; confirm whether the grounding is correct. If the grounding is not perfect, it may cause electric shock.

6. When the heat pump unit needs to be moved or reinstalled, please entrust the dealer or professionals to operate; if the installation is not perfect, it may cause the unit operation failure, electric shock, fire, injury, water leakage and other accidents.

7. Must not transform and repair, improper repair, will cause water leakage, fire, electric shock, injury and other accidents, be sure to entrust dealers or professional personnel to repair.

8. Do not remove any permanent instructions, labels or nameplates on the inside of the heat pump unit shell or the various panels.

5.2.3 Precautions

1, the power supply wiring must be equipped with a leakage protector with a rated current value not lower than the high operating current of the unit, and the grounding must be reliable, and keep dry to prevent leakage. Please often check whether the wiring is well coordinated. If the contact is bad, it will lead to overheating and burn out the devices, and even cause fire and other personal injury accidents;





2. In the place and wall where the water may splash, the installation height of the power socket should not be less than 1.8 meters, and ensure that the water will not splash on the socket, and can not be installed in the place where children may touch;







3, during the power heating period, the pressure safety valve relief hole may have water drops, this is a normal phenomenon, if a lot of leakage, please timely find professional personnel to repair, do not plug the relief hole, so as not to cause heat pump unit damage, leading to the occurrence of safety accidents. The drainage pipe connected to the pressure relief hole shall be kept tilted downward and installed in a







frost-free environment;

4. If the unit is equipped with power cord, when the power cord is damaged, the special power cord provided by the manufacturer must be used, and replaced by the service organization of the manufacturer or similar qualified professional repair personnel;
5. If the parts of the unit are damaged, please hand them over to the professional personnel for maintenance, and use the special maintenance parts provided by the company;
6. If the heat pump unit will not be used for a long time (more than 2 weeks), hot water pipe system may produce hydrogen, which is easily burning. In this case, in order to reduce the danger, it is recommended before using any electrical appliances connected with the hot water system, turn on the hot water faucet for a few minutes (such as 5~10 minutes). If there is hydrogen, then when the water begin to flow, there will be an abnormal sound like the air through the pipe. Do not smoke or light an open flame near the tap during the opening period.
7. Do not put your fingers, sticks into the air outlet or air inlet. Because the internal wind wheel runs at a high speed, it may lead to injury.
8. In case of abnormal situation (Scorching odor), immediately cut off the manual power switch, stop running, and contact the after-sales service department of the manufacturer. If the abnormal operation continues, it may cause an electric shock or cause a fire.
9. The unit can not be installed in a place where combustible gas is easy to leak. Once the combustible gas leaks, a fire may be caused around the unit.
10. Confirm whether the installation foundation for long-term use is firm. If the foundation is not solid, there may be a fall injury accident.

5.2.4 Required tools

No.	Tool Name	Picture	Function
0	Safety and industrial gloves		Protect your hands
1	Digital electric pen		Preliminary maintenance voltage, small one-word screw
2	Cross screwdriver (5 * 150)		Remove the crucifix screw
3	One-word screwdriver (5 * 150)		Remove one-word screw

4	Active wrench (10-inch)		Remove screws and so on
5	Active wrench (14-inch)		Remove the pipe valve, etc
6	Laryngeal forceps (20 inches)		Remove the pipe valve, etc
7	Long-nose pliers		Line cutting, terminal removal, etc
8	Hex wrench 4~12mm		Open the stop valve, valve, etc
9	Electric screw driver		Remove screws, etc

10	Clamp meter multi meter		Test current, voltage, resistance, capacitance, etc
11	Vacuum pump		Vacuum of the refrigeration system
12	High and low pressure gauge		Measure the refrigeration system pressure, vacuum, etc
13	Scissors		Cut strapping, thermal insulation cotton, etc
14	Band tape		Measure the distance, the length, etc
15	Marker pen		Record the data, mark, etc

Note: Other special tools are not listed, and the above tools can guarantee the basic maintenance and testing, etc.



The product shall be installed by the professional installation personnel according to the instructions.

Note: Correct installation is required to ensure safe operation. The requirements for the heat pump include:

1. Dimensions of the key connections.
2. Site assembly (if required).
3. Appropriate site location and clearance.
4. Proper electrical wiring.
5. Adequate water

This manual provides the information required to meet these requirements. Before proceeding with the installation, thoroughly check all the pre-installation preparations and review the installation steps.

4.3 Installation position



CAUTION!

1. Do not install the heat pump near the dangerous material and location.
 2. Do not install the heat pump under a deep sloping roof without a drain, which forces the rain and debris to pass through the unit.
 3. Place the heat pump on a slightly tilted flat surface, such as concrete or precast slab. This would allow proper drainage of condensed water and rainwater from the unit base. If possible, the floor shall be placed on the same or slightly above the level of the filtration system / equipment.
 4. The installation position, spacing and ventilation shall meet the technical requirements of the heat pump unit manufacturer.
 5. Avoid flammable gas leakage or environments with highly corrosive gases.
 6. Intelligent control components of the electrical system and the system shall avoid being directly affected by strong electric and magnetic fields.
 7. To facilitate maintenance and troubleshooting, there is no obstacles within the vertical distance of 2.5 meters from the unit for convenient ventilation.
 8. Keep away from densely populated areas, avoid areas prone to noise and vibration, and take noise reduction measures if necessary.
 9. Unfavorable natural conditions (such as heavy oil smoke, strong sandstorms and serious lampblack pollution) should be avoided.
 10. Safety warning signs shall be set up at the installation position.
 11. The installation position shall be convenient for the water supply pipe and the electrical connection.
 12. Give full consideration to the requirements of fire fighting, ventilation and drainage to facilitate maintenance and repair.
 13. Equipped with qualified power supply matching with the equipment to be installed. The power supply should be dedicated, with sufficient capacity and reliable grounding.
 14. The foundation or foundation of the installation site shall be solid, with sufficient bearing capacity, and the hollow structure or buried drainage ditch shall be adopted.
- Isolation measures shall be added at the connection between the heat pump and the foundation. The

process, use requirements, noise vibration amplitude, frequency characteristics, transmission mode, noise and vibration of the isolation measures shall meet the design requirements.

15. When the unit is installed on the roof or in the outdoor area, the lightning protection measures should be added.

4.4 Installation details

All of the criteria given in the following sections reflect the minimum clearance. However, each installation must also be evaluated, taking into account local prevailing conditions such as proximity and height of walls, and proximity to public access areas. The heat pump must be placed in all aspects to provide clearance for maintenance and inspection.

1. The heat pump installation area must have good ventilation and the air inlet/outlet must not be hindered.
2. The installation area must have good drainage and be built on a solid foundation.
3. Do not install the unit in areas accumulated with pollution like aggressive gas (chlorine or acidic), dust, sand and leaves etc.
4. For easier and better maintenance and troubleshooting, no obstacles around the unit should be closer than 0.5m. And no obstructions within 2.5m vertically from the unit for air ventilation(Fig.1).

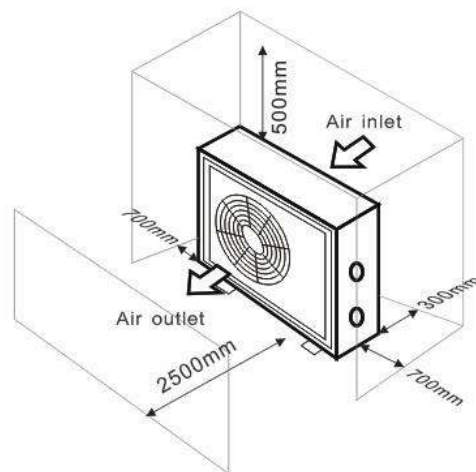

Figure 1

5. The installation foundation height of the unit shall be greater than 300mm and shall be greater than the local snow thickness.(It's up to the drain height and the snow height in local).
6. The heat pump must be equipped with shock-absorbing bushings to prevent vibration and/or imbalance;
7. The pipeline must be installed with appropriate support to prevent possible damage due to vibration. The pressure of tap water should be maintained above 200kPa. Otherwise, a booster pump should be installed;
8. The acceptable working voltage range should be within $\pm 10\%$ of the rated voltage;
9. For safety reasons, the heat pump unit must be grounded.
10. Heat pumps must be fitted with shock-proof bushing to prevent vibration and / or imbalance.
11. The installation position meets the fire protection requirements; The width of the main operating channel of the heat pump unit is 1.0-1.2m, and the width of the non main channel is not less than 0.8m.

The distance between the outer contour of the equipment and the switch gear or other electrical devices is 1.0m;

12. When installing adjacent units, the distance between the two units should be maintained at 1.0~1.2m.

13. The unit is equipped with a water flow switch inside, which does not need to be installed during installation;

14. If the unit does not operate in winter, the internal water of the system must be drained to prevent pipeline or component damage from freezing.

15. Distance from your swimming pool

The heat pump is normally installed within a perimeter area extending 7.5 m from the swimming pool. The greater the distance from the pool, the greater the heat loss in the pipes. Sometimes, as the pipes are mostly underground, the heat loss is low for distances within 30 m between the pool and heat pump, unless the ground is wet or the groundwater level is high. A rough estimate of the heat loss per 30 m is 0.6 kWh (2,000 BTU) for every 5 °C difference between the water temperature in the pool and the temperature of the soil surrounding the pipe. This increases the operating time by 3% to 5%.

4.4.1 General requirements

1. Read the operating instructions before installation, use, and maintenance.

2. The heat pump must be installed by a professional in accordance with the local electrical wiring specifications and this specification.

3. Before installation, please contact the local dealer center and check the complete packing before installation.

4. Do not use any method to accelerate the defrosting process or clean the cream (frost) unless specifically advised by the professional.

5. When repairs are needed, please contact the nearby after-sales service center.

6. The operation manual provided by the manufacturer must be strictly followed. Non-professional maintenance is prohibited.

7. The equipment shall be stored in a room without continuous fire source (e. g., open fire, illuminated gas furnace, open electric heater).

8. The storage environment of the equipment shall be kept ventilated to avoid direct sunlight.

9. Safety checks must be performed to minimize the hazard risk prior to maintenance or repairing the R32 heat pump.

4.4.2 Open the package and check it

1. The heat pump should be checked in a well-ventilated area (open doors and Windows). Fire source is strictly prohibited.

2. Before opening the cabinet, check whether the pressure value of the heat pump goes to zero and judge whether the refrigerant is leaking. If leakage is found, do not install a the heat pump.

Reference value: R290 ambient temperature -20~35°C, corresponding to gas pressure 2Bar~12Bar

Note: This pressure can be read on the pressure gauge next to the control heat pump panel. Under these conditions the water flow through the unit is also optimal.

Reference value: R290 ambient temperature -20~35°C
Corresponding to saturation pressure 2~12bar



3.The heat pump shall be checked for trace of damage and for good appearance.

4.4.3 Safety principles for installation

- 1.The installation site shall be well ventilated (open doors and windows).
- 2.The use of R290 refrigerant is prohibited in areas where fire sources exist.
- 3.When installing the heat pump, anti-static measures should be taken, such as wearing cotton clothes / anti-static clothes, wearing cotton gloves, wearing wireless electrostatic bracelet, etc.
- 4.The leak detector must be in working condition.
- 5.If R290 refrigerant leakage is found during the installation process, it should immediately test the concentration of the indoor side environment, and open the doors and Windows for ventilation until the safety level is reached.
- 6.If the refrigerant leakage affects the performance of the heat pump, the operation should be stopped immediately, and the heat pump must be returned to the service station for treatment.
- 7.The installation position of the heat pump should be easy for installation and maintenance, no obstacles around the inlet and exit of the unit, and not close to the heat source.
- 8.Do not be installed in a flammable and explosive environment.
- 9.When the heat pump is installed or repaired, when the length of the power line and the indoor and outdoor unit connection line is not enough, it must be replaced according to the original specifications. The connection and extension are strictly prohibited.

4.5 Drainage and Condensation

1. Condensation will occur from the evaporator when the unit is running and drain at a steady rate, depending upon ambient air temp. and humidity. The more humid the ambient conditions, the more condensation will occur. The bottom of the unit acts as a tray to catch rainwater and condensation.
2. Keep the drain holes, located on the bottom pan of the unit base, clear from debris at all times.
3. The chassis is designed with several drainage holes(Circled in red below), which can directly drain

condensate water and prevent water accumulation from causing freezing.

4. Preferably install the device in a well-drained place. To do this, it is advisable to provide a bed of gravel, sand or similar materials below said hole. If the drain hole of the heat pump is covered by a mounting base or by the floor, lift the unit to leave a free space of at least 100mm below it.

5. If it is installed on a terrace or facade, the condensate outlet must be led to a drain to avoid inconvenience and/or damage caused by the dripping of condensate water. If the installation is carried out in a region where the temperature can be below 0°C for a long period of time, do not connect the drainage outlet to the centralized water pipe, but directly drain to prevent the water pipe from freezing.

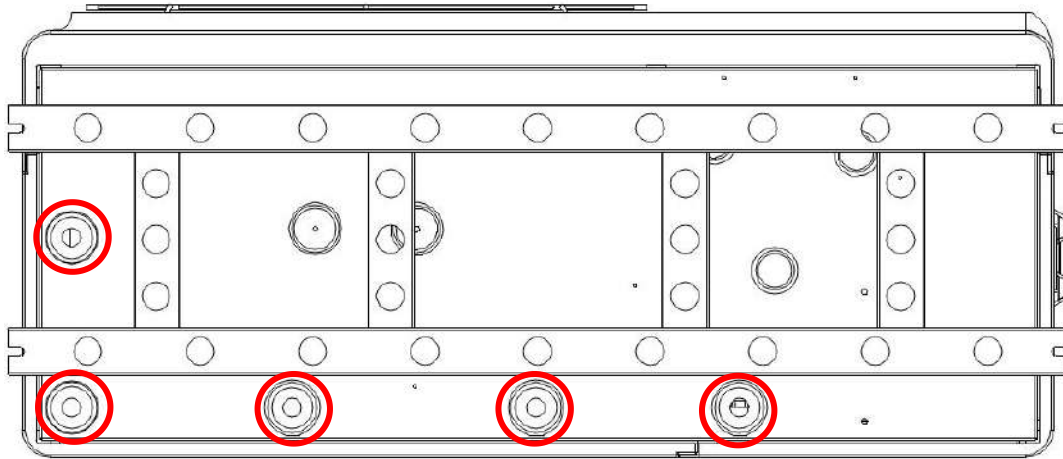

4.6 Water system connection

4.6.1 Installation Requirements

1. It is recommended to install quick connect fittings at the connection between the inlet and outlet.
2. Suggest using copper pipe or stainless steel or PPR pipes for water pipelines.
3. When water pressure exceeds 0.6MPa, please use reducing valve to reduce the water pressure **below 0.6MPa**.
4. Each part connected to unit needs to be connected with method of loose joint and installed with intermediate valve.
5. Ensure that all plumbing has been properly completed and then proceed to do a water leakage and pressure test.
6. All the pipelines and pipe fittings must be insulated to prevent heat loss.
7. Install a **drain valve** at the lowest point of the system to enable the system to be drained during freezing conditions.
8. It is recommended to install a **check-valve** to prevent reverse flow in the absence of water circulation.



Drain valve



Check valve

9. In order to reduce the back pressure, the pipes should be installed horizontally.
10. Minimize the elbows (90 degrees connections). If a higher flow rate is required, install a bypass valve.
11. **Water Flow Switch:** It is equipped with a flow switch to prevent the heat pump of running with inadequate water flow. It will turn on when the pool pump runs and shuts off when the pump shuts off.

4.6.2 Water pipe diameter

Model	Water Connection (mm)
PW010-KZXYC-H	Φ50
PW020-KZXYC-H	Φ50
PW030-KZXYC-H	Φ50
PW040-KZXYC-H	Φ50
PW050-KZXYC-H	Φ50
PW060-KZXYC-H	Φ50
PW070-KZXYC-H	Φ50
PW080-KZXYC-H	Φ50

4.6.3 Water quality requirements

1. When the water quality is poor, more sediment such as scale and sand will be generated. Therefore, water must be filtered and softened with a soft water device before flowing into the water system;
2. Before using the unit, the water quality should be analyzed, such as pH value, conductivity, chloride ion, Sulfate concentration, etc. The following are the water quality standards applicable to this unit.
3. The return water main pipe must be equipped with a **system filter** to keep the water quality, and ensure that the direction indicated by the filter arrow is consistent with the direction of the water flow inside the pipe. Sufficient maintenance space must be reserved around the filter.

4. The water quality of the swimming pool should meet the following basic requirements:

- (1) The sensory characteristics of the pool water are good;
- (2) The water in two pools must not contain pathogenic microorganisms;
- (3) The chemicals contained in the water of the three pools shall not pose a threat to human health.
- (4) The water quality requirements for swimming pools should comply with the following standards:

No.	Item	Limit value
1	Turbidity	1NTU
2	PH value	7.0~7.8
3	Urea	3.5 mg/L
4	Total colony count (36°C±1, 48 h)	200 cfu/ml
5	Total coliform group (36°C±1, 24 h)	Not detectable per 100ml
6	Alkalinity (以CaCO ₃ 计)	60~200mg/L

7	Calcium hardness (以CaCO ₃ 计)	200~450mg/L
8	Total dissolved solids	Not greater than 1500 mg/L of TDS in raw water
9	Water temperature	23°C~40°C
10	Redox potential	Not less than 650mV

4.6.3.1 Water quality pre-purification equipment - hair collector

Before filtering and purifying used swimming pool water, it should be pre purified through a hair aggregator.

(1) The setting of hair aggregators should meet the following requirements:

1. It should be installed on the suction pipe of the circulating water pump;
2. The filter cartridge (mesh) should be cleaned or replaced regularly;
3. If there are two circulating water pumps, they should be operated alternately.

(2) The construction of hair aggregators should meet the following requirements:

1. The structure should be simple and easy to disassemble;
2. The casing should be made of pressure resistant and corrosion-resistant materials. When made of carbon steel metal material, anti rust and corrosion treatment should be carried out;
3. The hole size of the filter cartridges should be 3-4 mm, and the filter mesh should be 10-15 mesh;
4. The filter cartridge (mesh) should be made of corrosion-resistant materials such as copper, stainless steel, and plastic.

4.6.4 Water quality-High speed filtering device

(1) The filter material inside the filtering device should meet the following requirements:

1. Large surface area, high porosity, strong pollutant interception ability, and long service life;
2. Free from debris and sludge, and free from toxic and harmful substances;
3. Good chemical stability performance;
4. High mechanical strength, wear resistance, and good compressive performance.

(2) The filtering speed of the filter should be selected according to the following regulations:

1. Competition pools, public pools, commercial pools, specialized pools, leisure and amusement pools, etc., should be filtered at a medium speed of 15-25m/h;
2. Private pools, massage pools, etc., can use 30-40m/h high-speed filtration.
3. The filter should be made of corrosion-resistant, impermeable, non polluting, and non deformable materials.

4.6.5 Water temperature requirements

The water temperature of swimming pools and leisure pools should be selected according to based on the purpose and type of the pool.

- (1) Indoor swimming pool

No	Type	Water temperature	
1	Public swimming pool	27~28°C	
	Adult pool		
	Dedicated swimming pool	28~29°C	
	Private swimming pool	29~30°C	
	Children's teaching pool	29~30°C	
2	Leisure amusement pool	Children's play pool	29~30°C
		Wave making pool	27~28°C
		Circulation pool	
		Slide drop pool	
		Massage pool	35~40°C
3	Multipurpose pool	25~28°C	

(2) Outdoor swimming pool

No	Type	Water temperature
1	With heating device	26~28°C
2	Without heating device	22~23°C

4.6.6 Swimming pool filling and replenishment

1. Open the exhaust valve and all valves on the water distributor first for exhaust air;
2. Make up water at the pipeline filling port(**Water pressure of tap water $\geq 0.2\text{MPa}$**);
3. During the water replenishment process, it is necessary to observe whether there is water overflow from the exhaust valve and drainage valve. If there is water overflow, it indicates that the system has been filled with water;
4. Close the exhaust valve and then take a look at the water pressure gauge. If the pointer is greater than 0.2MPa, close the makeup valve and the water pipeline already be emptied successfully.

Note: The water system pressure of the heat pump **design is 0.6MPa**.



Water pressure gauge

5.The time required for the initial filling of a swimming pool should be determined based on factors such as the nature of swimming use, pool size, water volume, and urban water supply or source conditions, in accordance with the following regulations:

- (1) Swimming pools should not exceed 48 hours;
- (2) The leisure swimming pool should not exceed 72 hours.

6.The amount of water that needs to be replenished daily during the operation of the swimming pool should be determined based on the amount of water lost due to surface evaporation, pool discharge, swimmers taking it out of the pool, and back washing of filtration equipment (such as when using pool water for flushing)

Daily replenishment of water in the swimming pool

No	Type	Environment	Water replenishment amount (percentage of swimming pool water volume) (%)
1	Public pool	Indoor	5~10
	Leisure pool	Outdoor	10~15
2	Children's Pool	Indoor	≥15
	Children's play pool	Outdoor	≥20
3	Private pool	Indoor	3
		Outdoor	5
4	Massage pool	Indoor	3~5
		Outdoor	5~10

Note: The initial filling of the swimming pool and the method of replenishing fresh water during use should meet the following requirements:

- 1.Indirectly fill or replenish water into the pool through a balance water tank, and replenishment water tank.;
- 2.When directly filling the swimming pool through the pool wall pipe opening, a back flow presenter(check valve) should be installed on the filling pipeline;
- 3.Independent water measuring instruments should be installed on the filling port and filling pipes of the swimming pool.
- 4.The volume of the **balancing water tank** is designed according to the on-site installation conditions. The balanced water tank should be constructed with materials that are smooth in surface, corrosion-resistant, non polluting, non deformable, and impermeable. When using reinforced concrete materials, the inner walls should be coated and lined with anti-corrosion coatings and materials that do not pollute water quality.

4.7 Circulation water pump selection

Circulating water pump: First, match the water flow of the water pump, then match the water head, and finally determine the power.

4.7.1 The circulating water flow

The water flow of the swimming pool water purification and circulation system should be calculated using the following formula:

$$q_c = \frac{V_p \cdot \alpha_p}{T_p}$$

q_c - Circulating water flow rate of swimming pool or leisure amusement pool (m³/h);

V_p - The water volume of a swimming pool or leisure amusement pool (m³);

α_p - Additional coefficient of water volume for pipes and equipment in swimming pools or recreational pools, $\alpha_p=1.05-1.10$;

T_p - Pool water cycle of swimming pool or leisure amusement pool (h), according to the standard, take $T_p=4\sim 6h$.

Remark: The water flow of the water pump shall not be less than the water flow calculated by the formula to ensure the circulation cycle of the swimming pool.

4.7.2 The water head

The head of the water pump shall not be less than the sum of the **geometric height of the water delivery, the resistance of the circulating system equipment, pipelines, and the outflow head.**

$$H_{\max} = (\Delta P_1 + \Delta P_2 + \Delta P_3) \cdot K$$

ΔP_1 —Unit water pressure drop head (please check product parameters, usually 1mH₂O=10KPa)

ΔP_2 —Horizontal pipeline resistance head (usually 5 meters head is required for every 100 meters of pipe length)

ΔP_3 —Total pipeline height difference(m)

K —Represents a safety factor ranging from 1.1 to 1.2

Remark:

- 1.The water pump should be corrosion-resistant, low-noise, energy-saving, and low speed centrifugal water pump.
- 2.Each water pump should be equipped with a flexible rubber short pipe, valve, hair catcher, and pressure vacuum gauge on its suction pipe; Flexible rubber short pipes, check valves, valves, and pressure gauges should be installed on the outlet pipe.
- 3.Vibration reduction and noise reduction measures should be installed on the pump unit and pipeline of the water pump.
- 4.The water flow velocity inside the water pump suction pipe should be 1.0~1.2m/s; The water flow velocity in the water pump outlet pipe should be 1.5-2.0m/s.



Water pump

4.8 Water pressure debugging

1. Before the experiment, the pipeline should be fixed, the joints should be exposed, and water distribution equipment should not be connected;
2. The pressure gauge is installed at the lowest point of the test pipe section, with a pressure accuracy of 0.01Mpa;
3. Slowly fill the pipeline with water from the lowest point of the pipe section, fully eliminate the air inside the pipeline, and conduct a water tightness test;
4. Slowly increase the pressure of the pipeline, and it is recommended to use a manual pump for pressure increase. The pressure increase time should not be less than 10 minutes;
5. After boosting to the specified test pressure and stabilizing for 1 hour, the pressure drop shall not exceed 0.06Mpa;
6. Under 1.15 times the working pressure, after stabilizing for 2 hours, the pressure drop should not exceed 0.03Mpa;
7. During the test, there should be no leakage at each connection;
8. Allow two additional pressures within 30 minutes to increase to the specified test pressure.

4.9 Pipe insulation requirements

1. All hot water pipelines must be wrapped with insulation materials;
2. Wrap the insulation pipe flat on the hot water pipeline and wrap the tie wrap around it;
3. Wrap the insulation skin material (such as thin aluminum plate, aluminum foil, etc.) flat on the pipeline that has already been wrapped with the insulation pipe;
4. The wall thickness of the insulation pipe should be reasonably selected based on the local climate, and insulation cotton thickness should be $\geq 20\text{mm}$; Finally, wrap a layer of wrapping tape on the insulation cotton.



5. Electrical Connections

5.1 Electrical Wiring Precautions

Before starting the installation of the heat pump, ensure that all high-voltage circuits are disconnected. Contact with these circuits may cause death or serious injury to the user, installation personnel, or others due to electric shock, and may also cause property damage.

When repairing a heat pump, mark all wires before disconnecting them. Wiring errors can lead to improper and dangerous operation. After maintenance, check and ensure normal operation.



WARNING —Risk of electrical shock or electrocution.



Ensure that all high voltage circuits are disconnected before commencing heat pump installation. Contact with these circuits could result in death or serious injury to users, installers or others, due to electrical shock and may also cause damage to property.



CAUTION — Label all wires prior to disconnection when servicing the heat pump. Wiring errors can cause improper and dangerous operation. Check and ensure proper operation after servicing.

5.2 Electrical Wiring

1. If the supply voltage is too low or too high, it can cause damage and/or result in unstable operation of the heat pump unit, due to high inrush currents on start up.
2. The minimum starting voltage should be above 90% of rated voltage. The acceptable operating voltage range should be within $\pm 10\%$ of the rated voltage.
3. Ensure the cable specifications meet the correct requirements for the specific installation. The distance between the installation site and mains power supply will affect the cable thickness. Follow the local electrical standards to select the cables, circuit breakers and isolation breakers.
4. The compressor, fan coil unit, electric heater and water pump all have AC-contactor and thermo relay protection.
5. Please ensure that all power supplies, electrical mainboard, compressors, motors, etc. are grounded.

5.2.1 Grounding and Over Current Protection

Note: Although the heat pump is electrically isolated from the rest of the swimming pool system, this only prevents the flow of electrical current to or from the water in the pool. Earthing is still required for protection against short-circuits inside the unit. Always provide a good earth connection.

In order to prevent electrical shock in case of leakage from unit, install the heat pump according to local electrical standard.

1. Do not interrupt the voltage supply to the heat pump frequently as this may result a shorter life expectancy of the heat pump.

2. When installing over current protection, ensure that the correct current rating is met for this specific installation.
3. The Compressor, fan coil unit and heat pump water pump all have AC-contactor and relay protection. Therefore, in the process of installation and debugging, firstly measure each of the aforementioned components' current, and then adjust the current protection range of the relays.

5.2.2 Single-phase power supply wiring

Connect the electrical wires to the terminal block marked POWER SUPPLY (L N);

Please use a 3-core power cable of appropriate length according to local safety regulations and connect to the terminal block of the unit;



Single phase power input



Power supply: Ensure the cable specifications meet the correct requirements for the specific installation. The distance between the installation site and mains power supply will affect the cable thickness.

Follow the local electrical standards to select the cables, circuit breakers and isolation breakers.

Model	Voltage (V)	Fuse or circuit breaker (A)	Max. current (A)	Wire diameter mm ² (with max. 15 m length)
PW010-KZXYC- E	220–240	16	7.2	3*1.5mm ²
PW020-KZXYC- E	220–240	16	11.1	3*2.5mm ²
PW030-KZXYC- E	220–240	25	14.0	3*2.5mm ²
PW040-KZXYC- E	220–240	25	16.0	3*2.5mm ²
PW050-KZXYC- E	220–240	32	20.2	3* 4 mm ²
PW060-KZXYC- E	220–240	32	25.2	3* 4 mm ²
PW070-KZXYC- E	220–240	40	29.7	3* 6 mm ²
PW080-KZXYC- E	220–240	40	31.8	3* 6 mm ²
PW060-KZXYC- E	370–390	16	9.8	5*2.5mm ²
PW070-KZXYC- E	370–390	16	11.6	5*2.5mm ²
PW080-KZXYC- E	370–390	20	12.5	5* 4 mm ²

5.2.4 Water pump wiring

Please use a 2-core power cable (1.5~2.0mm²×2) of appropriate length that meets local safety regulations. The water pump wire is a 220V signal wire, and if the power exceeds 500W, please connect it with a suitable relay or contactor externally. The water pump connection is as follows.

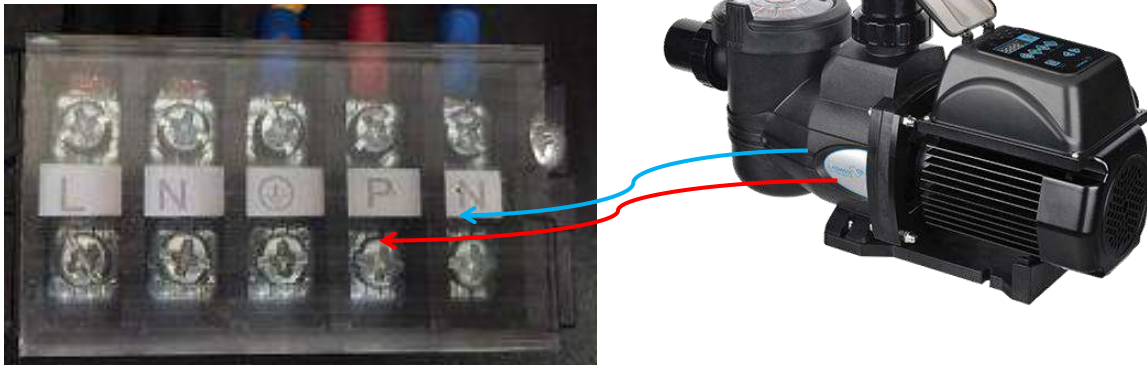

After completing the wiring, the user can Long press [⏻]+[⌚], enter "0814" to enter the engineering parameter settings on the wired controller and set P21 operating status of the water pump, as follows:

Parameter	Parameter Name	Set Range	Factory Setting
P21	Water Pump's Working Mode When Target Temperature Reached	1= Non Stop/2= Stop 3=Intermittent(Stop the water pump for 20 minutes and run it for 3 minutes)	3

Remark: The water pump is optional and requires customers to purchase additionally.

5.3 Temperature Sensor Position

The heat pump is designed with 8 temperature sensors at the factory, that are used to detecting the temperature and translate the temperature signal to electricity signal to the mainboard.

The installation positions of each temperature sensor and the resistance values measured at a 25°C ambient temperature are shown in the table below.

Description	Sensor	Location in heat pump	Resistance
Discharge Gas Temp. Sensor	T1	Compressor outlet pipe	50KΩ
Water Inlet Temp. Sensor	T2	Inlet Water pipe port	5KΩ
Heating Coil Temp. Sensor	T3	Evaporator pipe	5KΩ
Suction Gas Temp. Sensor	T4	Compressor inlet pipe	5KΩ
Cooling Coil Temp. Sensor	T5	Condenser pipe	5KΩ
Ambient Temp. Sensor	T6	On the fins evaporator	5KΩ
Water Outlet Temp. Sensor	T7	Outlet Water pipe port	5KΩ

Remark: For more environmental temperature resistance values, please refer to Appendix B.

4. Three phase system (PW060/070/080-KZXYC-E)

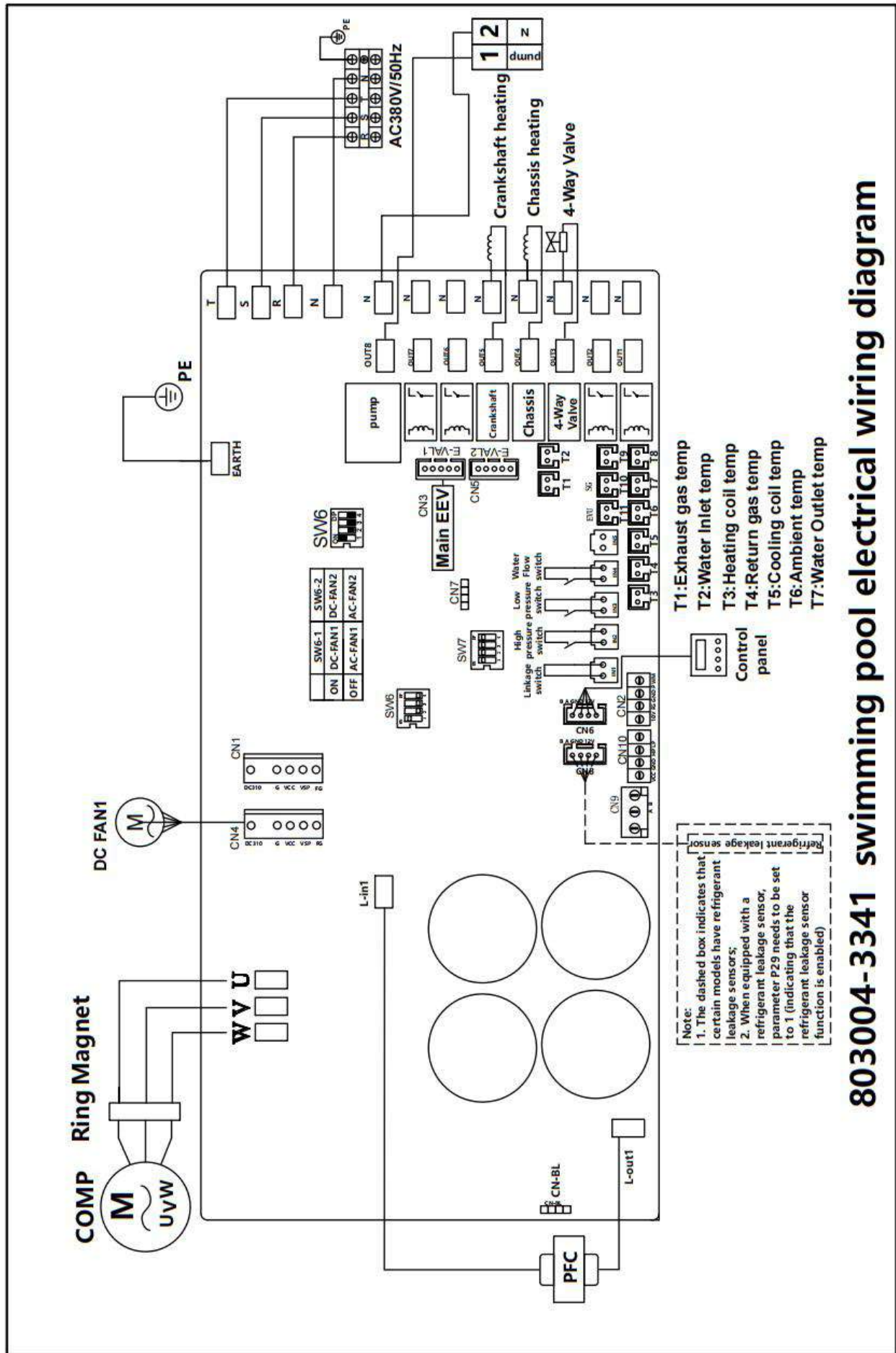

803004-3341 swimming pool electrical wiring diagram

NOTE:

(1)The above electrical wiring diagrams are only for your reference, please subject the heat pump to the posted wiring diagram.

(2)The swimming pool heat pump must be earthed well, although the unit heat exchanger is electrically isolated from the rest of the unit. Earthing the unit is still required to protect you against short circuits inside the unit. Bonding is also required.

Disconnect: A disconnect (circuit breaker, fused or un-fused switch) should be located within sight of and easily accessible from the unit .This is common practice on commercial and residential heat pumps. It prevents remotely-energizing unattended equipment and permits turning off power to the unit while the unit is being serviced.

6.Commissioning

6.1 Precautions

1. Trial operation can only be conducted after electrical safety inspection.
2. Do not block the inlet and outlet of the air, as this may cause the unit performance degradation or start the protection procedure that will make the machine unable to operate.
3. Ensure that all valves are opened, flush the water system piping, and ensure that the water cleanliness meets the requirements.
4. Fill and empty the water system to ensure that there is no air in the water system.

6.2 Trial Operation

1. Use the control panel to control the operation of the machine, and check the following items according to the operation instructions.
2. Check whether the control panel on/off button is normal.
3. Check whether the function key on the control panel is normal.
4. Whether these parameters are normal.
5. Whether the drainage system is normal.
6. The temperature difference between inlet and outlet should be (4-7°C).
7. Whether the vibration and sound are normal during the operation.
8. Whether the discharged air, noise and condensate generated during the operation will affect the neighbors.
9. Whether there is any refrigerant leakage.

Note: When the unit stops and starts, the unit has protection function and the compressor is delayed for 3 minutes.

Note: Please refer to Appendix A for detailed commissioning.

7.Heat pump operation

7.1 Overview

The controller is specially designed for the swimming pool heat pump series, with features as below:

- ✓ Heating and cooling mode;
- ✓ Could show and change the running and setting parameters of the system,easy for user to install and test.
- ✓ With automatic protection and fault warning function ;
- ✓ With strong system protection function, like compressor delay protection, high pressure, low pressure, sensor protection,water flow detect etc;
- ✓ The communication distance between the heat pump unit and remote controller shouldn't be less than 100 meters. Communication port is 485 communication.
- ✓ Strong anti-interference, stable performance.

7.2 Basic Model of System Control Chart

◎ System Chart

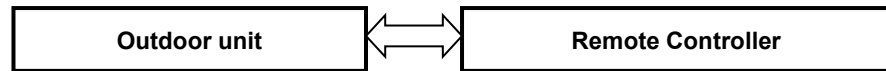







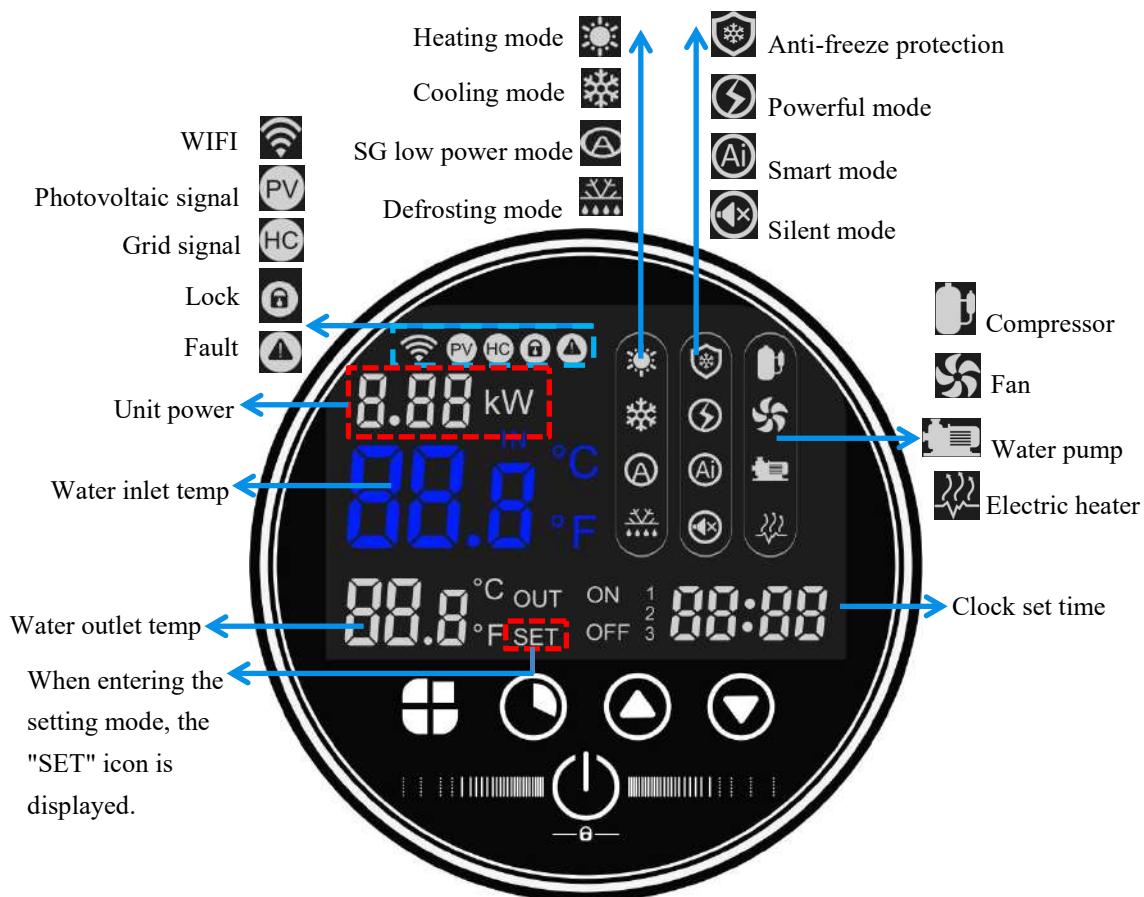









◎ Control Principle













- The Outdoor unit is run according to the wired controller's order;
- The wired controller could change the running parameters and send the running parameters to the outdoor unit;
- The outdoor unit could detect the running condition and send the info or fault to the wired controller.





7.3 Wired Controller (Wired controller (with WIFI))



Icon	Meaning	Icon	Meaning
	Heating mode		Cooling mode
	Fault		Defrosting mode
	Anti-freeze protection		Powerful Mode
	Standard Mode		Silent Mode
	Compressor		Fan
	Water Pump		Electric heater
	WIFI		Photovoltaic signal (EVU)
	Grid signal (SG)		Lock screen
	Clock		

7.4 Key Button



Button	Name	Function
	Power button	<ul style="list-style-type: none"> ➤ Long press "  " for 3 seconds to switch on/off; ➤ In other interfaces, short press "  " to return to the main interface;
	Up key	<ul style="list-style-type: none"> ➤ When the machine is turned on, in the main interface, press "  " to set the temperature in the current mode;
	Down key	<ul style="list-style-type: none"> ➤ When the machine is turned on, in the main interface, press "  " to set the temperature in the current mode;
	Clock key	<ul style="list-style-type: none"> ➤ In the power on/off state, short press "  " to set the clock , and combine "  " and "  " to set the clock ; ➤ In the power on/off state, long press "  " to set the timer , and

		combine "  " and "  " to set the timer ;
	Query Key	➤ When the machine is turned on, long press "  " to switch modes;

7.5 Parameter query and setting









7.5.1 User parameter query

In the power on/off state, directly press the "  " key on the main interface to enter the parameter query state.

At this time, press " "  , "  " to query the parameters of A01-A16 , as follows ;

Code	Name	Scope	Display value
A01	Inlet water temperature	- 30~99°C	Measured value
A02	Outlet water temperature	- 30~99°C	Measured value
A03	Ambient temperature	- 30~99°C	Measured value
A04	Exhaust gas temperature	0~125°C	Measured value
A05	Return gas temperature	- 30~99°C	Measured value
A06	External coil temperature	- 30~99°C	Measured value
A07	Inner coil temperature	- 30~99°C	Measured value
A08	Main expansion valve opening	0 ~ 480	
A09	Enthalpy increase expansion valve opening	0 ~ 480	
A10	Compressor current		
A11	Heat sink temperature		
A12	DC bus voltage value		
A13	Actual speed of press		
A14	DC fan 1 speed		When there is a single fan, it is displayed here. When there are two fans, it is the speed of fan 1
A15	DC fan 2 speed		When there is a single fan, it is displayed as 0. When there are two fans, it is the speed of fan 2
A16	Refrigerant gas concentration	0 ~ 100%	
A17	Low pressure value		
A18	Low pressure conversion temperature		







7.5.2 Parameter query and setting : (can be set on or off, password: 0814)

In the power on/off state, you can simultaneously press and hold the "  + "  " keys for 3 seconds to enter the password input state. At this time, the tens digit "0" of the hour in  the clock area flashes. At this time , short press the "  " key to shift the position. The ones digit of the hour digit flashes. Combine "  " and "  " to input "8", and then press the "  " key again . The tens digit of the minute digit flashes and input "1". Press the "  " key again . The ones digit of the minute digit flashes and input "4". After the password is entered correctly, press the "  " key again to confirm the password and enter the engineering parameter query interface (if the password is incorrect, it will return to the main interface);

Code	Parameter	Scope	Default value
P1	Temperature difference	1~18°C	1°C
P2	Cooling set temperature	8°C~35°C	27°C
P3	Heating set temperature	5°C~40°C	27°C
P4	Inlet water temperature compensation	-5°C~15°C	0°C
P5	Defrost cycle	20~90MIN	45MIN
P6	Defrost entry temperature	-9°C~-1°C	-3°C
P7	Defrost time	5~20MIN	8MIN
P8	Defrost exit temperature	1°C~40°C	20°C
P9	Defrost environment and coil temperature difference	0°C~15°C	9 °C
P10	Ambient temperature for defrosting	0°C~20°C	17°C
P27	Smart grid function	0:Disable 1:Enable	0
P29	R290 refrigerant leakage sensor function	0:Disable 1:Enable	1

7.6 Clock Setting

Clock settings: (can be set power on or off)

short pressing the "  " key, the clock will be set. The hour will flash first, indicating that the hour value of the current time can be adjusted by the "  " and "  " keys. Each time the "  " key is pressed, the hour will increase by one, and each time the "  " key is pressed, the hour will decrease by one. If the "  " key or "  " key is pressed for a long time, the hour will increase or decrease automatically. After setting the hour value,

press the "🌙" key again; the minute value will flash at this time, indicating that the minute value of the current time can be adjusted by the "⬆️" and "⬇️" keys. After setting the minute value, press the "🌙" key again to end.



Note: If there is no operation on the controller for 10 seconds, the set time will be automatically saved and the main interface will be returned.

7.7 Timer power on/off settings

Press and hold the "🌙" button for 3 seconds to enter the timer setting:

Enter the timing selection, then the "ON 1" clock "hour" flashes, and you can set the hour by pressing "⬆️" and "⬇️". Press the "🌙" key again to switch to the clock "minute", and you can set the minute by pressing the "⬆️" and "⬇️" keys.



Press the "🌙" key again to switch to the "OFF 1" setting: the clock "hour" flashes, and you can set the hour by using the "⬆️" and "⬇️" keys; press the "🌙" key again to switch to the clock "minute" and you can set the minute by using the "⬆️" and "⬇️" keys;



The settings for other time periods are similar.

Press "  " to exit or confirm.

Press on the main interface to display the number of currently set timing periods;

To cancel the timer setting:

When the set power-on time and power-off time are the same, the timing setting for the current time period is canceled .

7.8 Smart Grid (SG-Ready)

When the smart grid function (parameter P27) is enabled, the heat pump starts to run the smart grid function.

The heat pump determines the power status through below different four SG and EVU signal status, and adjusts the operating four modes of the heat pump according to different power grid statuses. It can store energy well, monitor energy use and allocate it reasonably, and reduce energy consumption.

The SG and EVU ports are connected to **smart meters** and photovoltaic **inverters** to achieve combined control of photovoltaic power and city mains power. As shown in the following figure.

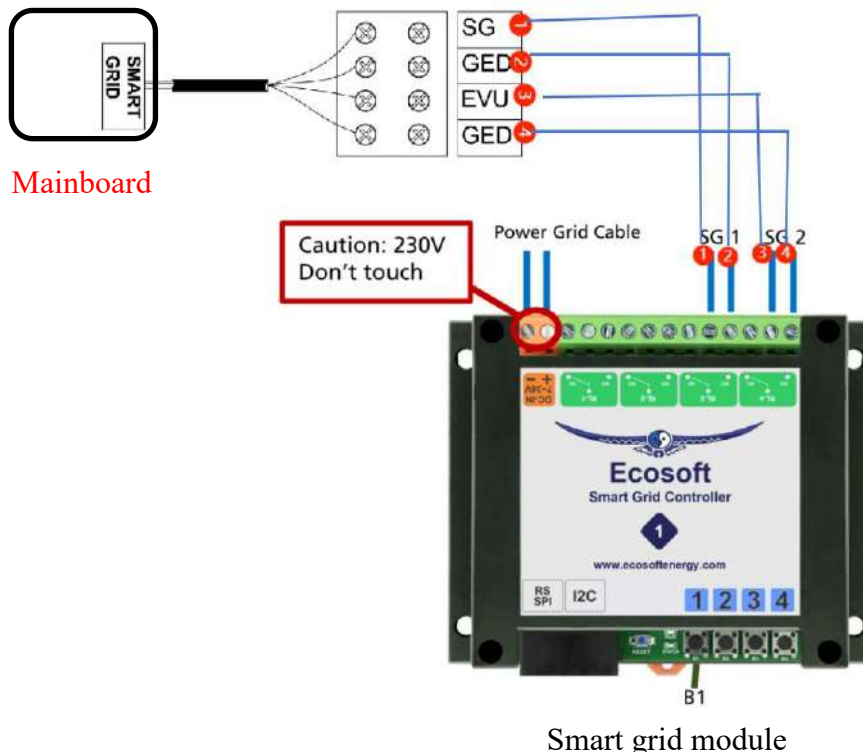



SMART GRID				
Mode	EVU	SG	Running status	
Working Mode 1	ON	OFF	Force shutdown	Heat pump forced to shut down compressor and fan



				(Low power mode, )
Working Mode 2	OFF	OFF	Normal operation	Heat pump working properly
Working Mode 3	OFF	ON	Enhanced Mode	Heat pump running in powerful mode
Working Mode 4	ON	ON	Forced to open	Heat pump running in powerful mode

7.9 Key Operation



7.9.1 Locking and unlocking keys

Press the " + " keys simultaneously for 3 seconds to enter the lock screen state, and press them simultaneously for 3 seconds again to exit the state;





7.9.2 Forced defrosting

- 1) Press and hold the " and " keys at the same time to enter the forced defrost mode;
- 2) When entering defrost mode, " is displayed.

7.9.3 Temperature unit switching (can be set when on or off)

In the power-off state, on the main interface, press and hold " and " for 3 seconds to switch between Celsius and Fahrenheit.



7.9.4 No operation screen off function (can be set when on or off)



- 1) The factory default setting of the remote controller is “no operation, no screen off”;
- 2) Press and hold the " + " keys for 5 seconds at the same time to enter the three-minute inactivity screen off function;
- 3) Press and hold the " + " keys for 5 seconds again to exit the three-minute inactivity screen off function, and repeat this cycle;

7.9.5 Manual electric heating function





On the main interface, press and hold " for 3 seconds to manually turn on/off the electric heating function.

7.9.6 Operation mode switching

Long press " " and " for 3 seconds on the main interface to switch between operating modes: Powerful, Smart, and Silent modes.



When in powerful operation mode, it displays ""; when in silent mode, it displays ""; and when in intelligent operation mode, it displays ".

7.9.7 Restoring parameters to factory settings

In the off state, press and hold the " key + " key + " key + " key for 3 seconds to restore the factory settings. The buzzer will sound twice in succession and all parameter values will return to the default values.

7.9.6 Forced Exit Preheating

When the system power down time meets the conditions(Default power cut off for more than 4 hours), the system enters the preheating state. At this time, the compressor icon "" flashes to indicate that it has entered the preheating state. The main board will start the crankshaft heating belt of the compressor to heat the lubricating oil and prevent damage caused by the engine and direct operation jamming.

During the system preheating process, If it is necessary to terminate, user can use the wired controller to press and hold the "" and "" keys simultaneously to force the system to exit this preheating.

 **WARNING:** Please note that after the heat pump is powered off for more than 4 hours, if the ambient temperature is too low and the compressor is not preheated, starting the compressor directly may cause the compressor to get stuck, damage the compressor or mainboard, and other poor situations. Please pay attention to the preheating function.

7.10 Users' Guide

7.10.1 Rights and Responsibility

(1) To ensure you have the service in guarantee period, only the professional server and technology staff can install and repair the unit. If you infract this request and cause any loss and damage, our company will not be claimed any responsibility.

(2) After receiving the unit, check if have damage on shipment and all parts are complete; any damage and lack of parts please notice the dealer in written.

7.10.2 User Guide

1. All safety protection device are set in unit before leaving factory, don't adjust by yourself.
2. Unit have enough refrigerant and lubricating oil, don't fill or replace them; if need fill owing to leak, please refer to the quantity on nameplate (if refill refrigerant, need re-vacuum).
3. External water pump must connect with the message of unit, or else easy show various water lack alarm.
4. Regular clean water system according to maintenance request.
5. Pay attention to antifreeze when the environment temp. is less than zero in winter.
6. Safety Precautions
 - A User can't self-install the unit, ensure agent or specialized install company to do, or else maybe cause safety accident and affect the use effect.
 - B When install or use the unit, please check if the power is corresponding with unit power.
 - C The main power switch of unit should install leakage protector; the power cord must meet unit power request and national standard and local Fire & Safety Regulations.
 - D Unit must have ground wire; don't use the unit if no ground wire; forbid connect the ground wire to null line or water pump.
 - E The main power switch of unit should set much higher 1.4 meter (child don't touch it), to prevent child play it and cause danger.
 - F More than 52°C hot water can cause damage, hot/cold water must be mixed then use it.
 - G When unit is soaking, please contact the factory or maintain department, you can use it again after maintain.
 - H Forbid insert any tools into fan fence of unit, fan is dangerous. (child special care)

I Don't use the unit if turn off the fan fence.

J To avoid electric shock or cause fire, don't store and use fixture, oil paint and petrol etc. combustible gas or liquid around the unit; don't throw the water or other liquid on the unit and don't touch the unit by wet hand.

K Don't adjust the switch, valve, controller and internal data except company server or authorized staff.

L If safety protection device often start up, please contact factory or local dealer.

8. General Maintenance

The R32 DC inverter swimming pool heat pump unit is a highly automated device. Regular and effective maintenance on the unit will greatly improve the operation reliability and service life of the unit.

During the maintenance process, pay more attention to the following important tips:

1. The water filter should be cleaned regularly to ensure that the water quality is clean and avoid the damage caused by the blockage of the filter element.
2. Users shall not change the internal structure or wiring of the equipment. All the safety protection devices have been set up before leaving the factory, and changes on them are strictly prohibited. We shall not assume any responsibility for the equipment damage caused by user adjustment.
3. The unit shall clean the surface of the evaporator regularly (every 1-2 months). If the unit is operating in a dirty or oily environment, professionals shall clean the evaporator with designated detergents to ensure the performance and efficiency of the unit.
4. Regularly check the feeding and exhaust device of the water system to prevent air from entering the system, leading to reduced water circulation or water circulation failure, and affecting the cooling and heating efficiency and working reliability of the unit.
5. The intelligent control system can automatically analyze various protection problems in daily use, and display the fault code on the controller. The unit can recover by itself. No maintenance is required for the piping within the unit under normal operating conditions.
6. The power supply and electrical wiring of the unit should be checked regularly to ensure that the wiring is firm and the electrical components are normal. If abnormal, it should be repaired or replaced, and the unit shall be reliably grounded.
7. During the operation of the unit, check all kinds of parts regularly. Check whether the working pressure of the refrigerant system is normal. Check the pipe joint and air injection valve for grease. Ensure that there is no refrigerant leakage in the refrigerant system.
8. Check whether the unit is firmly installed. Do not pile up any debris around the equipment to prevent the blockage of the air outlet. The environment around the unit shall be kept clean, dry and ventilated.
9. When the unit will not be used for a long time to rest after a period of operation, the water in the water system should be drained. And turn off the power supply, cover the equipment. When the unit needs to be used again, wait for the water system to fill the water, until the unit is thoroughly checked, start and preheat for at least 6 hours and restart the unit only after everything is OK.
10. No special repair or maintenance on the water system of the unit unless the water pump is damaged. It is recommended to clean or replace the water filter regularly when it is very dirty or blocked.

Precautions:

1. The unit shall be equipped with a specialized power supply. The voltage range shall be within $\pm 10\%$. The switch shall be an automatic air switch. The set current shall be 1.5 times of the operating current and equipped with no phase protection device. No knife switch is used in the unit.
2. It must be powered up for at least 12 hours before seasonal operation. If the machine does not work for a long time in winter, you must drain all the water in case the pipe and the unit are frozen and damaged. The controller shall be consistent with the unit. If the heating machine stops working in winter, no power shall be removed to avoid freezing and damage.
3. Heat pump switch can not be operated frequently, not more than 4 times within 1 hour. Electrical cabinet shall be protected from damp influence.
4. It is strictly prohibited to flush the DC inverter air source heat pump with water to avoid electric shock

or other accidents.

8.1 Daily inspection of heat pump

1. Before starting up, check the temperature parameters, switch status, and load output:
 - A. The temperature displays are not significantly different from the ambient temperature
 - B. It is normal to measure with a multi-meter that the high and low pressure switches are normally closed, while the water flow switch is normally open
 - C. Main parts load display off
3. Check if the voltage is normal before starting up.
4. After starting up, check if the water pressure is normal, listen for any abnormal sounds when starting each part, and check if the current matches the nameplate markings after running smoothly;
5. Check if all parameters are within the normal range according to system and user parameters after operation.

8.2 Maintenance of Main Structural Components

1. The surroundings of the unit should be kept clean to avoid storing debris. Avoid blocking the air outlet and affecting heat exchange efficiency.
2. It is strictly prohibited to connect air energy heat pump units to substandard water sources such as excessive water, lake water, river water, and groundwater.
3. When maintaining the unit, the main unit must be in a power off state. If the shutdown time is long, the water in the unit pipeline should be drained, the power should be cut off, and a protective cover should be put on. When running again, conduct a comprehensive inspection of the system before starting up.

4. Heat exchanger

- A. Regularly clean the water side heat exchanger, it is recommended to clean it every 3 months, and use a hot oxalic acid solution with a concentration of 15% at 50 °C -60 °C to clean the heat exchanger, then start the built-in circulation pump of the unit to clean for 3 hours, and finally rinse it three times with tap water.
- B. When installing pipelines, it is recommended to reserve a three-way valve interface to prevent cleaning solution from entering the water tank, and seal one interface with a screw plug in case of connection during cleaning.
- C. Do not use corrosive cleaning solution for heat exchangers or water tanks.
- D. The air side heat exchanger should be cleaned regularly (3-6 months) to maintain good heat exchange efficiency. Before cleaning, the power must be cut off. When cleaning surface stains, please use a damp cloth dipped in a small amount of neutral cleaning agent to gently scrub, do not use gasoline or other solvents. Finally, wipe dry with a dry cloth to keep the unit dry.

5. Compressor

Open the junction box, check if the terminals are tightly connected and if there are signs of rust or blackening, and check if the resistance values between the three-phase windings are the same.

8.3 Maintenance of Main Electrical Components

1. General inspection of air circuit breakers, AC contactors, and relays: Check whether the wiring terminals are tight, rusted, and burnt black. Close the switch and check whether the input and output of each phase of the electrical terminal are connected; Check whether the coil of the AC contactor and relay is sensitive and fully engaged.
2. **Capacitor:** Check for bulging and oil leakage.

3. **Mainboard:** Check if the power light is on, if the fuse is blown, and if there are any burnt black marks on the board surface.
4. **Wired controller:** Check whether the buttons are sensitive, whether the interface is not fully displayed, and whether the temperature can be set.
5. Check if the primary voltage and secondary voltage match the nameplate.

8.4 Maintenance of Main Water pipeline Components

1. **Water replenishment device:** Check if the replenishment pressure is $\geq 0.2\text{MPa}$ and if the check valve is working normally;
2. **Filtering device:** The pipeline filter device in the pipeline should be cleaned regularly to prevent blockage. Suggest cleaning **every 15-30 days**. Clean the pressure gauge connection pipe and observation window once a month, and check the working condition of the exhaust valve;
The accuracy of pressure gauge and flow meter readings should be checked every 3 months and corrected;
3. **Exhaust device:** Check if it can exhaust normally. If it cannot exhaust normally, remove and clean the filter inside;
4. **Water pump device:** Check whether it operates smoothly, whether the rotation direction is correct, and whether it is blocked or idling. The water pump should be repaired once a year to check the wear of bearings and mechanical seals, and to remove all kinds of impurities. If necessary, vulnerable parts should be replaced. When the running time of the water pump exceeds 500h, the bearings should be lubricated.
5. **The hair aggregators** should be cleaned once a day.

6. Dosing control equipment

Water quality testing equipment should be maintained, cleaned, and calibrated every two weeks;
The water quality testing and analysis toolkit should be kept clean and the quality and expiration date of reagents should be checked regularly;
Chemical dosing points should be regularly cleaned and should not experience blockages or siphoning effects.

7. Ozone generator

- (1) Seal the tank with water every 10 days;
- (2) When the equipment runs for 250-1000 hours, the inlet air filter should be cleaned or replaced;
- (3) When the equipment runs for 500-2000 hours, the internal filter should be replaced and the equipment should be cleaned once;

When carrying out the above tasks, **the power should be cut off** and the supplier should complete the above tasks;

- (4) The ozone system and sexual process should record the following parameters every 2 hours:

- 1) Voltage, current, and frequency of ozone equipment;
- 2) Ozone production and concentration;
- 3) The redox potential in the effluent of the reaction tank, the inlet and outlet of the activated carbon absorption tank, or the mixture of ozone disinfected water and non ozone disinfected water.

8.5 Maintenance of anti-freeze

1. Keep powered on

Please do not turn off the power when the heat pump is temporarily out of use or when it is not in use, as the unit is equipped with anti freeze protection function. Only when the unit is running normally or the circulation pump is running normally, can the unit ensure that water does not freeze in cold weather. Therefore, the water temp can be appropriately lowered to save power. (It is recommended to set the water

temp to 25-30 °C when not in use for a short period of time, which not only saves electricity but also prevents freezing.).

2.Pipeline insulation

Adequate insulation measures should be taken for the pipeline. Please pay attention to checking whether the insulation wrapping of the pipeline is in place to avoid freezing blockage of the pipeline. The pipeline insulation mainly uses insulation cotton and polyurethane foam.(Small pipes are generally insulated with insulation cotton, while large pipes are insulated with polyurethane foam.)

3.Shutdown precautions

If the user is not at home for a long time, the heat pump needs to be shut down for a long time, or if the power outage lasts for more than 15-30 minutes, the user must drain the water in the heat pump pipeline to prevent the water from freezing when the unit stops running. After thoroughly draining the water, the power should be turned off to prevent the unit from running incorrectly due to water shortage.

8.6 Refrigerant Charging

Refrigerant plays an important role in the cooling or heating process, and the lack of refrigerant directly affects the effect of cooling or heating. Before adding the refrigerant, please note the following:

- (1) The work shall be done by a professional personnel.
- (2) If there is insufficient refrigerant, check leakage in the system. If yes, repair before charging refrigerant, otherwise the unit will run out of refrigerant again after short operation.
- (3) Do not add too much refrigerant, otherwise it may cause other faults, such as high pressure, poor performance, etc.
- (4) There must be no air in the refrigerant system because air can cause abnormal high pressure, damage the gas pipe and affect the cooling or heating efficiency.
- (5) If there is a refrigerant leakage in the room, keep the window open for several minutes, evacuate persons at the site and evacuate the refrigerant naturally.

Note: Always use a weight scale to measure the refrigerant amount entering the unit.

The swimming pool heat pump has been charged with refrigerant before leaving the factory, and the charging amount is shown in the table below.

Model	Power supply	R290 Refrigerant amount from factory
PW010-KZXCYC-E	230V/1Ph/50Hz/60Hz	280g
PW020-KZXCYC-E	230V/1Ph/50Hz/60Hz	380g
PW030-KZXCYC-E	230V/1Ph/50Hz/60Hz	460g
PW040-KZXCYC-E	230V/1Ph/50Hz/60Hz	750g
PW050-KZXCYC-E	230V/1Ph/50Hz/60Hz	850g
PW060-KZXCYC-E	230V/1Ph/50Hz/60Hz	1000g
PW070-KZXCYC-E	230V/1Ph/50Hz/60Hz	1500g
PW080-KZXCYC-E	230V/1Ph/50Hz/60Hz	1500g
PW060-KZXCYC-E	380V/3Ph/50Hz/60Hz	1000g
PW070-KZXCYC-E	380V/3Ph/50Hz/60Hz	1500g
PW080-KZXCYC-E	380V/3Ph/50Hz/60Hz	1500g

Note: If there is a leakage during the operation of the heat pump, please power off it and then drain the refrigerant in the system and vacuum it, next it is necessary to refer to the refrigerant charging amount on the nameplate.

9. Error Code List and Trouble shooting

9.1 Main electronic control ports and functions

9.1.1 Diagram for main board

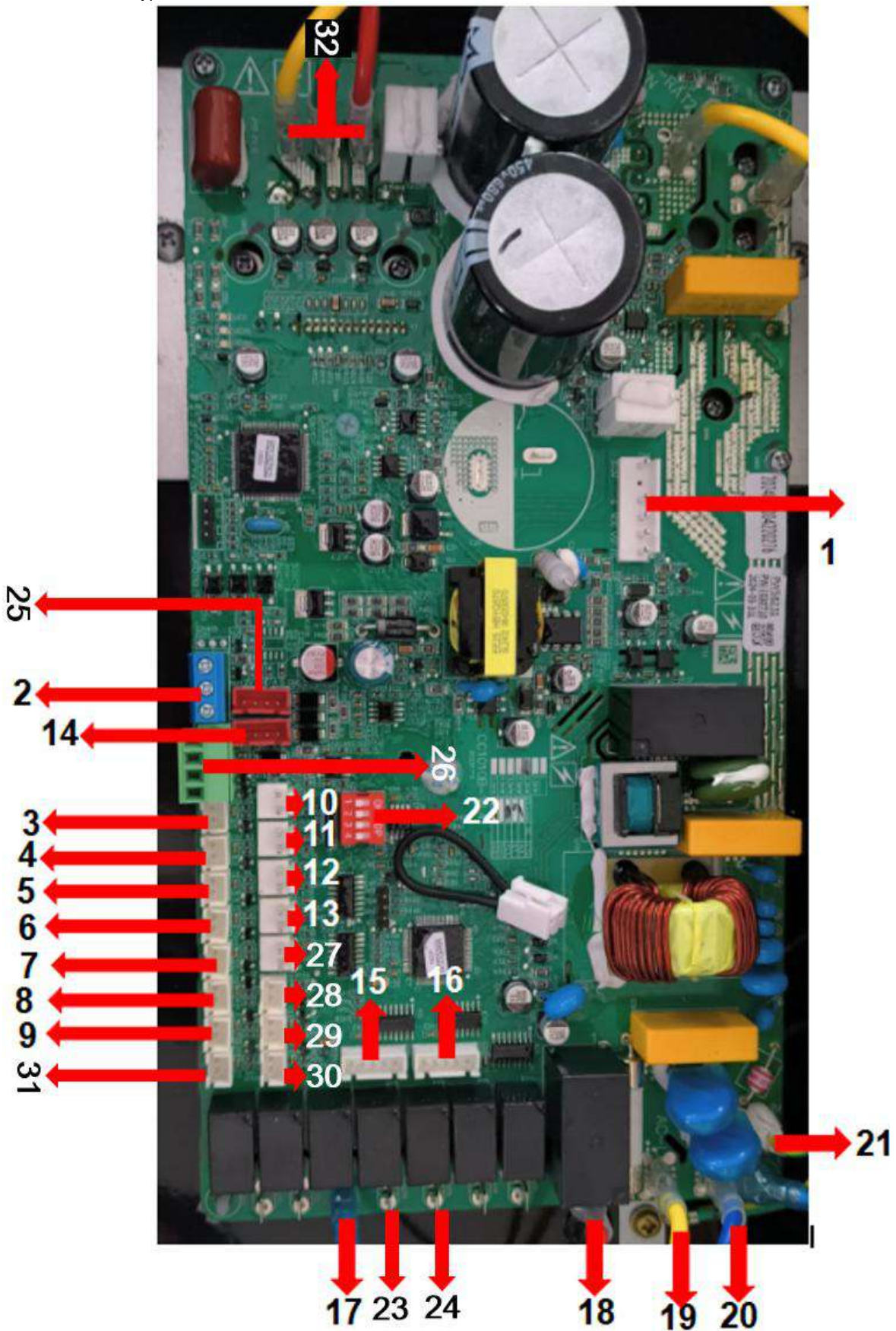

Item no.	Descriptions	Item no.	Descriptions
1	Fan	17	4-way valve control port
2	CN485	18	Circulation pump control port
3	Discharging Gas Sensor	19	AC-L Line
4	Water Inlet Sensor	20	AC-N Line
5	Heating Coil Sensor	21	GND for ground connection
6	Suction gas sensor	22	Switch 1 for the DC or AC fan
7	Cooling Coil Sensor	23	Chassis heating control port
8	Ambient Sensor	24	Crankshaft heating control port
9	Water Outlet Sensor	25	Refrigerant leakage sensor port
10	Emergency switch	26	Reserved
11	High pressure switch	27	Reserved
12	Low pressure switch	28	EVU port
13	Water flow	29	SG port
14	CN6 port for the control panel	30	Reserved
15	Reserved	31	Reserved
16	EEV connection	32	Compressor power terminals(UV W)

9.1.2 Diagram for power supply

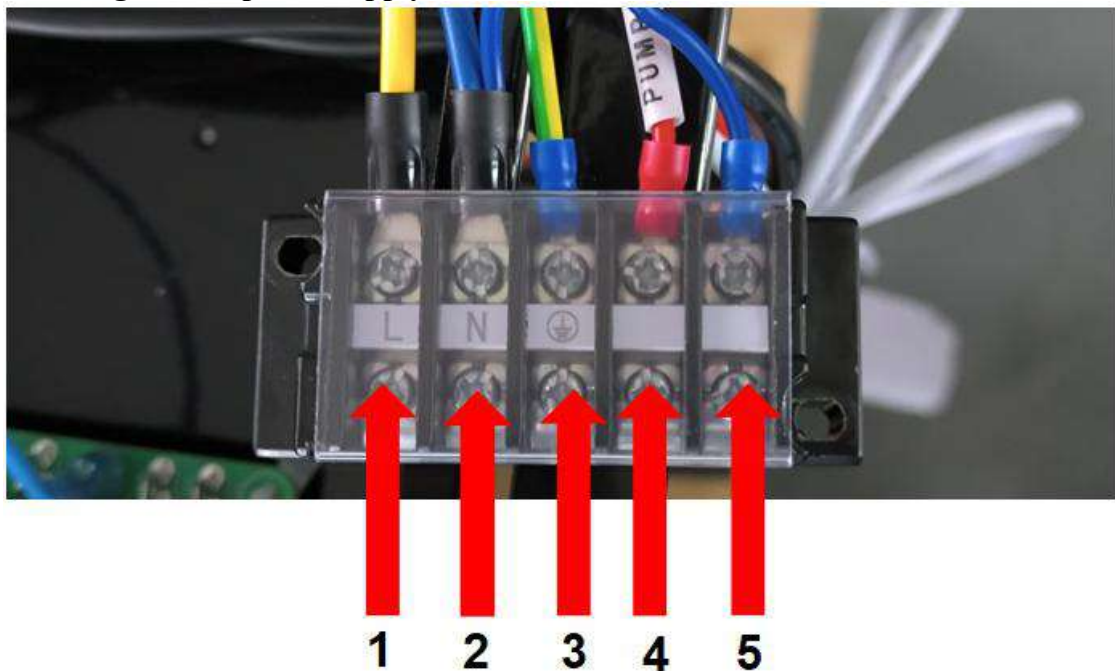

Item no.	Descriptions	Item no.	Descriptions
1	Power cable live line L	4	Power cable live line L
2	Power cable zero line N	5	Power cable zero line N
3	Earth line 		

9.1.3 Diagram for SG terminal



Item no.	Descriptions	Item no.	Descriptions
SG	SG signal connection	EVU	EVU signal connection
GND	Signal ground wire connection	GND	Signal ground wire connection

9.2 Controller Error Codes

(1) If there's error in the heat pumps, the error code and error definition will be displayed in the main interface, and saved the record in FAULTY column inside the SETTING interface.

(2) The following Common Error Codes will be displayed on the controller panel:

Error Code	Definition of Error or Protection
Er 03	Water flow failure
Er 04	Antifreeze in winter
Er 05	High pressure fault
Er 06	Low pressure fault
Er 09	Communication failure
Er 10	Communication failure of frequency conversion module (alarm when communication between main board and drive board is disconnected)
Er 12	Exhaust temp too high protection

Er 15	Water inlet temp. sensor fault
Er 16	Evaporator coil temp. sensor fault
Er 18	Exhaust temp. fault
Er 20	Abnormal protection of frequency conversion module
Er 21	Ambient temp. sensor fault
Er 23	Cooling outlet water temp. Super-cooling protection
Er 27	Outlet water temp. sensor fault
Er 29	Return gas temp. sensor fault
Er 32	Heating too high outlet water temp. protection
Er 33	Outdoor Coil temp. too high protection
Er 35	Compressor current protection
Er 42	Cooling coil temp. sensor failure
Er 74	Refrigerant sensor failure
Er 75	Refrigerant leakage protection

E20 fault will display the following error codes at the same time, the error codes will switch every 3 seconds. Among them, error codes 1-128 are display in priority. When error codes 1-128 don't appear, then error codes 257-384 can show. If two or more error codes appear at the same time, then display error codes accumulation. For example, 16 and 32 occur at the same time, display 48.

Detailed error code list for Er 20:

Error code	Name
1	IPM over current
2	Compressor synchronization is abnormal
8	The compressor output phase is missing
16	DC bus with low voltage
32	DC bus with high voltage
64	The heating sink temperature is too high
128	Heating sink temperature failure
257	Communication failure
258	The AC-input phase is missing
260	AC input over-current
264	The AC-input voltage is low
288	IPM over heat
320	The compressor peak current is too high
384	The PFC module temperature is too high

9.3 Owner Inspection

We recommend that inspections on heat pumps are done frequently, especially after abnormal weather conditions. The following basic guidelines are suggested for your inspection:

1. Make sure the front of the unit is accessible for future service.
2. Keep the top and surrounding areas of the heat pump clear of all debris.
3. Keep all plants and shrubs trimmed and away from the heat pump especially the area above the fan.
4. Keep lawn sprinklers from spraying on the heat pump to prevent corrosion and damage.
5. Ensure that the ground wire is always properly connected.
6. The filter must be maintained on a regular basis in order to ensure clean and healthy water to protect the heat pump from damaging.
7. Keep inspecting power and electrical components' wiring to make sure their normal operation.
8. All the safety protection devices have been set up; please refrain from changing these settings. If any changes are needed, please contact the authorized installer/agent.
9. If the heat pump is installed under roof without a gutter, ensure that all measures are taken to prevent excessive water from flooding the unit.
10. Do not use this heat pump if any electrical part has been in contact with water. Contact an authorized installer/agent.
11. If the increase of power consumption is not due to colder weather, please consult with the local authorized installer/agent.
12. Please turn off the heat pump and disconnect it from the mains power supply, when not in use for a prolonged period of time.

9.4 Troubleshooting

Use the following troubleshooting information to resolve issues/problems with your DC Inverter swimming pool heat pump.

WARNING — RISK OF ELECTRICAL SHOCK OR ELECTROCUTION.



Ensure that all high voltage circuits are disconnected before commencing heat pump installation. Contact with these circuits could result in death or serious injury to users, installers or others, due to electrical shock and may also cause damage to property.

DO NOT open any part of the heat pump as this may result to electrocution.

1. Keep your hands and hair clear of the fan blades to avoid injury.
2. If you are not familiar with your heater:
 - a) **DO NOT** attempt to adjust or service the unit without consulting your authorized installer/agent.

- b) **PLEASE** read the complete Installation and/or User's Guide before attempting to operate service or adjust the heater.

IMPORTANT: Turn off the mains power supply to the DC Inverter swimming pool heat pump prior to attempting service or repair.

9.4.1 Troubleshooting of fault codes

Fault code	Name	Description	Solution
Er 03	Water flow fault	electronic control system: Water flow switch failure	Check the water flow switch and replace if need
		water system: 1. The water flow is too small 2. wrong connected on inlet and outlet pipe 3. Has air inside the pipes system 4. Pipe block	1. Check the temperature difference between the inlet and outlet water temperature 2. Check whether the inlet and outlet water pipes are improperly connected 3. Discharge the air inside pipes (exhaust valve) 4. Clean the pipe (filter valve)
Er 04	Antifreeze protection	Ambient temperature is too low, non-abnormal fault	Normal protection shows that the host power can be automatically restored
Er 05	High pressure fault	1. Throttle switch is too small or blocked 2. Condenser fins are dirty or blocked with debris 3. Insufficient condensing air volume or fan failure 4. Too much refrigerants	1. Check the throttling device 2. Clean the condenser heat sink 3. Check whether the fan is abnormal 4. Fill the refrigerant according to the volume on the nameplate
		electronic control system: High voltage switch failure	Reconnect the cable to the HP switch or replace the HP switch
		water system: 1. The water flow is too small 2. The water supply system has been blocked 3. The water side heat exchanger has scale 4. Inlet temperature probe drops (the actual water temperature is too high)	1. Check the temperature difference between the inlet valve and the inlet and outlet water 2. Replace the filter 3. Scaling 4. Reconnect the water inlet temperature probe
Er 06	Low pressure fault	1. The evaporator fin is dirty, dusty, and seriously blocked 2. Refrigerant leakage and dirty wing blockage lead to poor defrosting	1. Clean the fins of the evaporator 2. Find the leakage point, weld it well, and then fill in the refrigerant
		Electronic control system: low-pressure switch fault	Check the low pressure switch and replace it if damaged
		water system:	1. Check the temperature difference

		<ol style="list-style-type: none"> 1. water flow too weak 2. The return water temperature is too low 	<p>between water and outlet water and adjust the water flow</p> <ol style="list-style-type: none"> 2. Check the actual water inlet and outlet temperature
Er 09	Communication fault	<ol style="list-style-type: none"> 1. Poor contact or damage of the communication cables 2. The main board and control panel are damaged 	<ol style="list-style-type: none"> 1. Check and replace the communication cable 2. Replace the motherboard and the control panel
Er 10	Communication fault of the frequency conversion module (alarm when the communication between the outer plate and the drive board is disconnected)	<ol style="list-style-type: none"> 1. The communication cable connector between the main board and the drive board has a bad contact or falls off 2. The communication cable is damaged 3. The motherboard or drive board is damaged 	<ol style="list-style-type: none"> 1. Reconnect the cable between the motherboard and the drive board 2. Replace the communication cable 3. Replace the motherboard or the drive control board
Er 12	The protective effect of the exhaust gas temperature is too high	<ol style="list-style-type: none"> 1. System refrigerant leakage 2. The system is dirty and blocked 3. Insufficient cooling oil of the compressor 4. The resistance value of the exhaust probe is offset, and the water inlet temperature probe drops 	<ol style="list-style-type: none"> 1. Refrigerant supplement (should it be checked for any leakage points?) 2. Replace the filter 3. Add the cooling oil to the compressor 4. Replace the exhaust probe and reconnect the water inlet temperature probe
Er 15	Inlet water temperature sensor fault	The sensor plug contact or fall off, the sensor is damaged	Check and replace the inlet water temperature sensor if need
Er 16	Evaporator coil temperature sensor fault	The sensor plug contact or fall off, the sensor is damaged	Check and replace the external coil temperature sensor if need
Er 18	Exhaust temperature sensor fault	The sensor plug contact or fall off, the sensor is damaged	Check and replace the exhaust gas temperature sensor if need
Er 20	Abnormal protection of the frequency conversion module	Internal fault of IPM module is shown in the table below	/
Er 21	Ambient temperature sensor fault	The sensor plug contact or fall off, the sensor is damaged	Check and replace the ambient temperature sensor if need
Er 23	Cooling outlet water temp. Super-cooling	1. If the effluent temperature is higher than the protection value of the system, and the water flow is small;	<ol style="list-style-type: none"> 1. Check whether the water valve or water pump has been started 2. Clean the pipe and discharge the air

	protection	2. There is air or blockage in the pipe 3. The inlet water temperature probe is closed	from the pipe 3. Reconnect the water outlet temperature probe
Er 27	Outlet water temperature sensor fault	The sensor plug contact or fall off, the sensor is damaged	Check and replace the outlet water temperature sensor
Er 29	Return gas temperature sensor fault	The sensor plug contact or fall off, the sensor is damaged	Check and replace the return air temperature sensor
Er 32	Heating outlet water temperature is too high protection	1. The effluent temperature is higher than the system protection value, the water flow is weak, and the pump body is abnormal 2. There is air or blockage in the pipe system 3. The inlet water temperature probe is closed	1. Check whether the water valve or water pump has been started 2. Clean the pipe and exhaust the air from the system 3. Reconnect the water outlet temperature probe
Er 33	The outdoor coil temperature is too high	The temperature of the condenser is higher than the set value, usually appear with Er32, priority display Er32	Solution as Er32
Er 35	Compressor current protection	1.The incoming voltage supply is too low 2. Compressor is overloaded 3. Thermal relay is damaged	1. Check if the incoming voltage supply is too low, if so, repair. 2. Check if the compressor is overloaded and repair. 3. Check whether the thermal relay is damaged, if so, replace.
Er 42	Cooling coil temp. sensor failure	The sensor plug contact or fall off, the sensor is damaged	Check and replace the cooling tube temperature sensor
Er 74	Refrigerant sensor failure	Not "0" If no communication is detected for 1 minute, a refrigerant sensor failure is reported	Check whether the R290 sensor wiring is normal
Er 75	Refrigerant leakage protection	If the R290 concentration > R40 [R290 concentration is too high] (default 15%), then "R290 leakage fault" will be reported.	1. Check for refrigerant leaks and repair refrigerant leaks 2. This fault will not be automatically restored unless the power is off.

Troubleshooting and Maintenance of Common Error Codes

E03
Water flow failure



Maintenance:

Water pipe

1. Check whether the water pipe valve is fully open or not, ensure smooth water flow.

2. Check whether the temperature difference between the inlet and outlet water is within the range of 4~7 °C or not. If the temperature difference between the inlet and outlet water is too large, it indicates that the water flow maybe too low due to unobstruction, and the heat of the heat exchanger cannot be taken away in time, so it is necessary to clean the water pipe or exhaust air (pipeline exhausting and external water pump exhausting).

E03
Water flow failure



3. Check whether the head and flow of the water pump is enough or not. If the flow rate and the head is not enough. Pay attention to the installation position and direction of the water pump. The water pump must be installed at the inlet of the unit rather than outlet.

Electronic control part:

Electric control: after shut down the unit, check the water flow switch. Find the water flow switch terminal on PCB main circuit board, pull out the terminal, and short the terminal instead. Turn on the heating mode of the unit again for 5 minutes and check whether the water temperature difference is between 4-7 degrees Celsius or not. If it is normal, determine the water flow switch installation is bad or fault, need to be installed or replaced;

E05
high pressure
failure

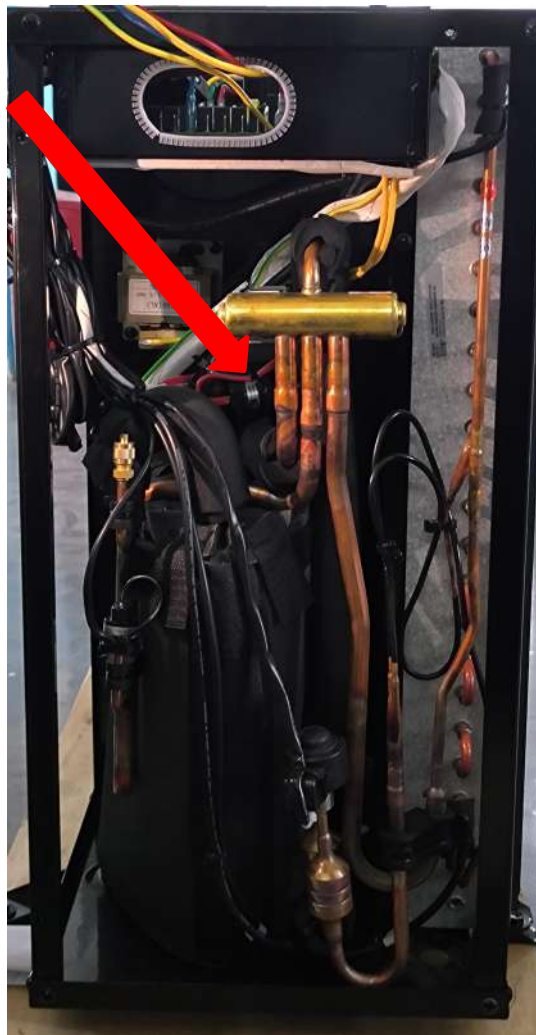

Electronic control:

First Steps:

1. Check whether the high pressure switch is damaged or the sensor wire is broken or not. Make sure the wiring terminals are connected correctly (Red IN2)

2. Check whether the position of the inlet temperature probe is correct or falls off (the inlet pipe of the unit). Make sure they are connected correctly;



E05
High pressure
failure

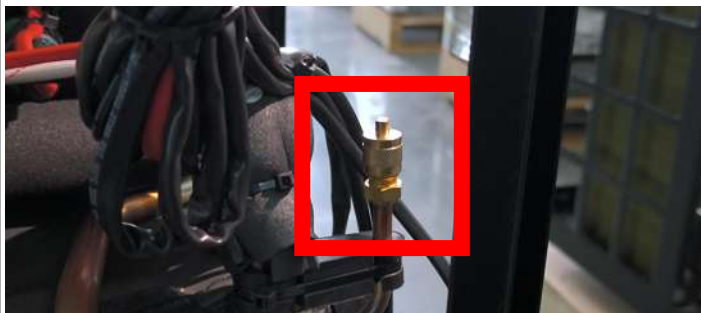
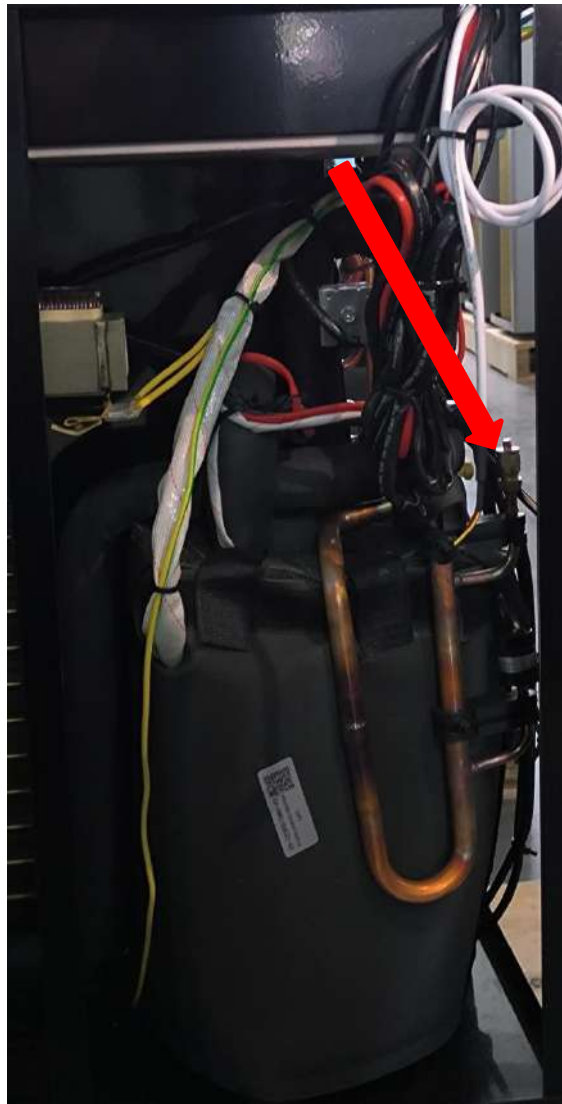

System checking:

1. After turning off the heat pump for 10 minutes, check whether the refrigerant pressure gauge parameters of the unit are normal, and connect to the needle valve inspection port with pressure gauge to measure whether the refrigerant in the system is normal or not (operated by professionals).

Danger warning:
Since it will be in contact with R290 refrigerant, make sure there is no open flame, good ventilation, and operate in a safe environment.

E05
High pressure
failure

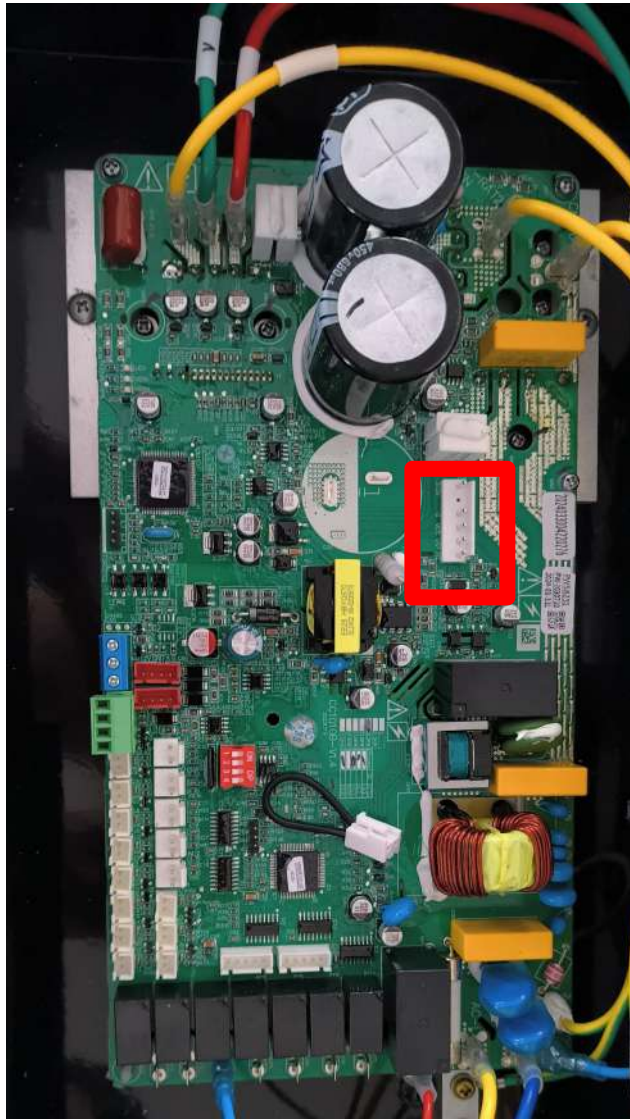

2. While the unit is running, check whether the fan is operating normally or not, or check the fan speed parameter through the controller. If the fan speed parameter is 0, check whether the fan terminal wiring is secure or not after power off.

<p>E05 High pressure failure</p>	 <p>Water pipe diameter: PW010~080, the pipe size is $\phi 50$</p>	<p>Water Connection:</p> <ol style="list-style-type: none"> 1. After opening heating mode for 5 minutes, check whether the temperature difference between the inlet and outlet water is between 4 and 7 degrees Celsius. If the temperature difference is too large, maybe the water is not smooth or the water flow is too small. 2. When the unit is on, check whether there is any abnormal noise or not when the water pump is running, and whether the water flow is sufficient or not. If the flow and head of water pump are not enough, the unit needs to be replaced with a suitable matching water pump. Pay attention to the installation position and direction of the water pump: (1) the water pump must be installed at the inlet of the unit rather than outlet. 3. Check whether the diameter of the water pipe is too small or not (to avoid small water flow). Make sure the water pipe connection is fairly smooth.
<p>E06 Low pressure failure</p>		<ol style="list-style-type: none"> 1. Check whether the low pressure switch is damaged or the sensor wire is broken or not. Make sure the wiring terminals are connected correctly (Red IN3).

E06
Low pressure
failure

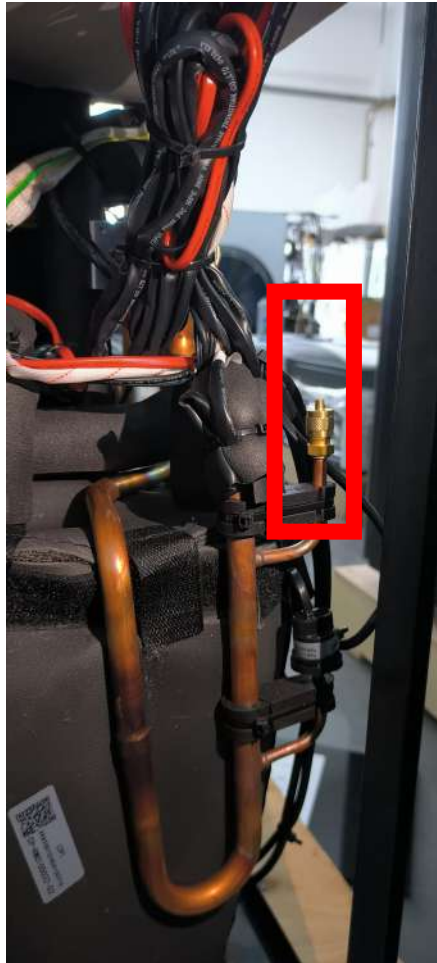

2. After the unit is turned off and stabilized, take a photo of the pressure gauge pressure data. If it approaches 0 bar, it indicates a refrigerant leak.

3. Or after turning off the heat pump for 10 minutes, check whether the refrigerant pressure gauge parameters of the unit are normal, and connect to the needle valve inspection port with pressure gauge to measure whether the refrigerant in the system is normal or not.

If it is lower than normal, it indicates a refrigerant leak. Please find the location of the pipe leak, repair it and refill the refrigerant according to the maintenance instructions (operated by professionals).

Danger warning: Since it will be in contact with R290 refrigerant, make sure there is no flame, good ventilation, and operate in a safe environment.

E09
Communication
failure between
Display and PCB

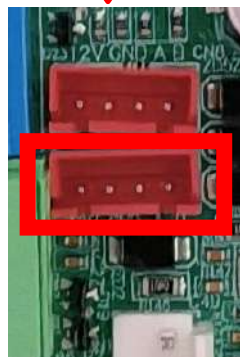

1. Check the connection of the communication line between the wire controller and the main board. If the communication line is damaged, the terminal falls off or the connection is bad, please replace the communication line and check again;

2. Measure the voltage between main circuit board and controller with multi-meter. If the voltage output is 12V DC, recheck after replacing the wire controller; otherwise please recheck after replacing the main circuit board;

E10 communication failure of inverter drive module (alarm when communication between display and PCB are disconnected)

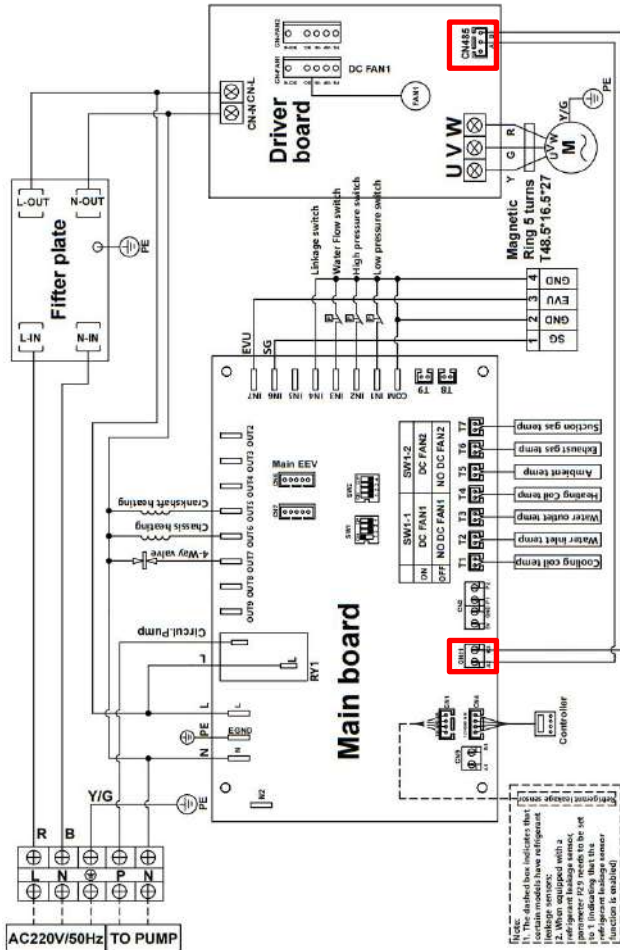

1. The connector of the communication cable between the main board and the driver board is in poor contact or the communication cable is damaged, Reconnect the cables or replace it with a new one;
2. The main board or driver board is damaged, need to replace a new board.

E12
Exhaust gas
temperature too high
protection

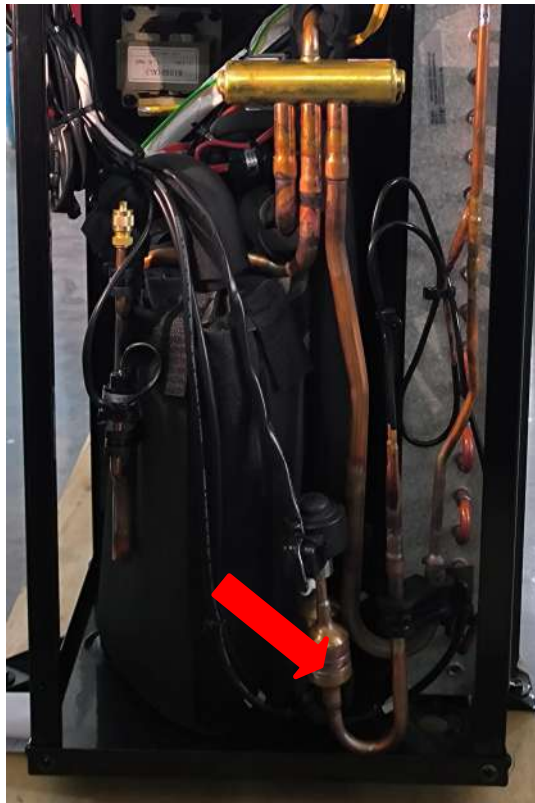

The filter

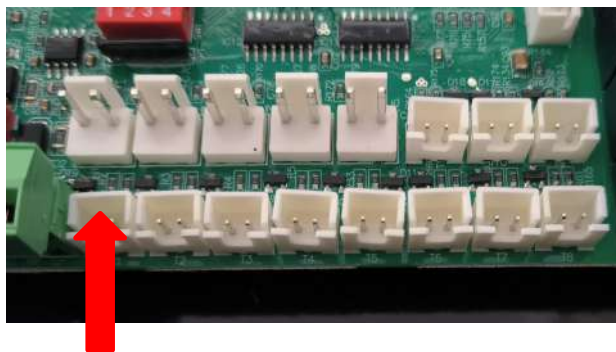
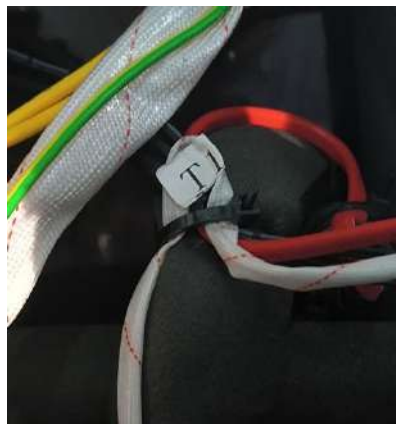

1. After turning off the machine for 10 minutes, check whether the refrigerant pressure gauge parameters of the unit are normal, and use the pressure gauge to measure whether the system refrigerant is normal. (If the refrigerant is below the normal value and the refrigerant is leaked, please check whether there are leakage points in each pipeline. The professional personnel are responsible for repairing the welding leakage point and recharging the refrigerant.)

Caution: This operation involves handling R290 refrigerant. Prior to commencing the operation, ensure no open flames, adequate ventilation, and conduct inspections only after confirming environmental safety.

2. The refrigerant circuit of the heat pump cooling system is blocked, necessitating the replacement of the filter. (Professional personnel are responsible for the maintenance operation to replace the filter and recharge the refrigerant.)

3. Check whether the exhaust temperature sensor probe (T1 is for PW010-PW060, T6 is for PW070-PW080) is damaged or detached. After shutting down the unit and disconnecting the power supply, locate the T1 terminal on the main board and unplug it. Then, use a multi-meter to measure the resistance value (normal resistance value is 50K Ω) to verify correctness. If the resistance value is abnormal, replace the exhaust temperature sensor.

E15
Water inlet
temperature failure

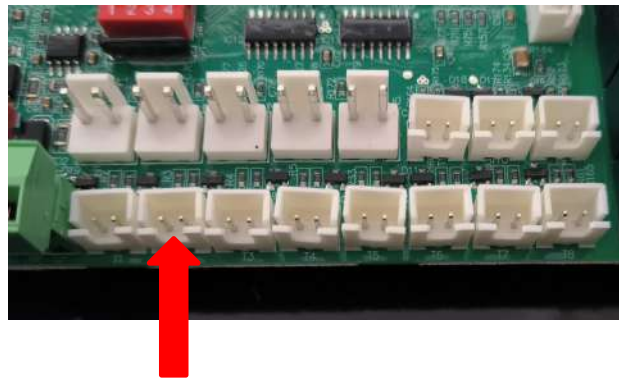
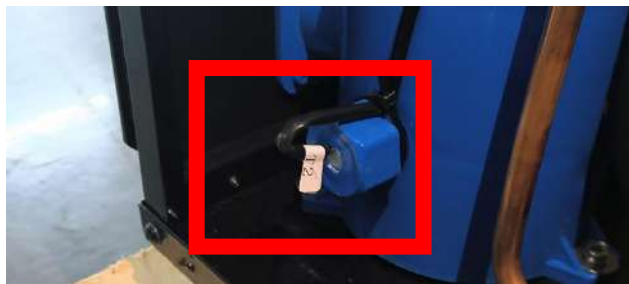

1. Check if the probe wiring is damaged;

2. Check the connection between the temperature sensor and the main board;

3. Check the resistance value of the temperature sensor ($5\text{ K}\Omega$). If the resistance value is too low or too high, it indicates that the sensor has a problem and needs to be replaced.

E16
Evaporator coil
temp. sensor fault

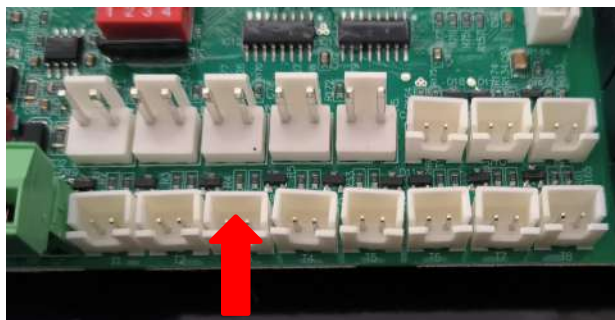
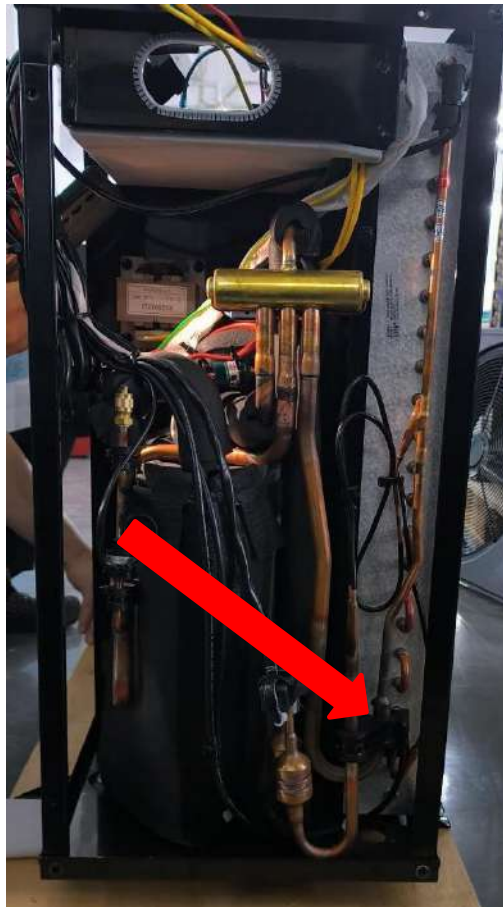

1. Check if the probe wiring is damaged;

2. Check the connection between the temperature sensor and the motherboard

4. Check the resistance value of the temperature sensor (5 K Ω). If the resistance value is too low or too high, it indicates that the sensor has a problem and needs to be replaced.

(T3 is for PW010-PW060, T4 is for PW070-PW080)

E18
Exhaust
temperature
failure

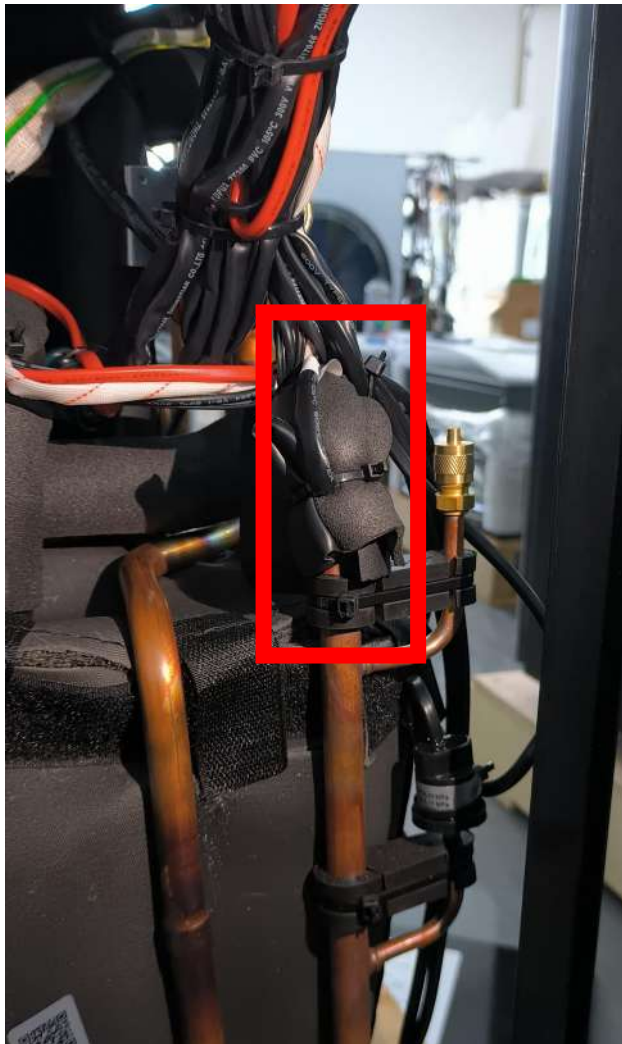

1. Check if the probe wiring is damaged;

2. Check the connection between the temperature sensor and the motherboard

2. Check the resistance value of the temperature sensor (50 K Ω). If the resistance value is too low or too high, it indicates that the sensor has a problem and needs to be replaced.

(T1 is for PW010-PW060, T6 is for PW070-PW080)



Er 19
DC fan motor failure



1. Check whether the DC fan wiring on the main board is normal;
2. Check if there is any fault to the capacitor, if yes, then replace it with a new one with same specification

Er21
Ambient
temp sensor
failure

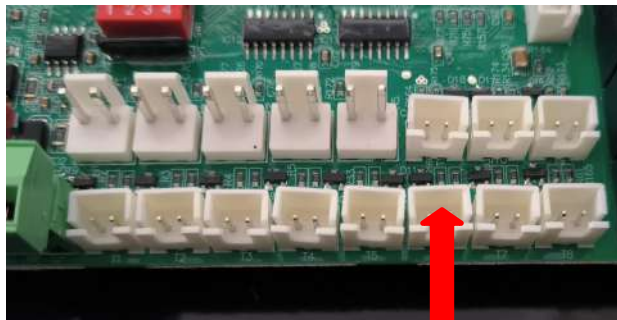
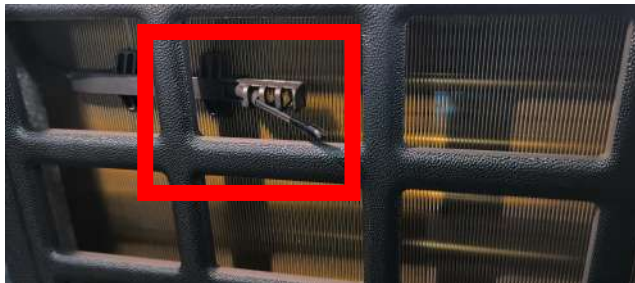

1. Check if the probe wiring is damaged;
 2. Check the connection between the temperature sensor and the motherboard
 3. Check the resistance value of the temperature sensor (5 K Ω). If the resistance value is too low or too high, it indicates that the sensor has a problem and needs to be replaced.
- (T6 is for PW010-PW060, T5 is for PW070-PW080)

Er23
Cooling outlet
water temp.
Super-cooling
protection



1. The outlet water temp exceeds the system's protection threshold, low water flow rate, water pump anomaly. Check if the water valve or water pump is open.

2. The water pipeline has air or blockage, emptying and cleaning the blockage.

2. Check the outlet water temperature probe if it's normal.

(T7 is for PW010-PW060, T3 is for PW070-PW080)

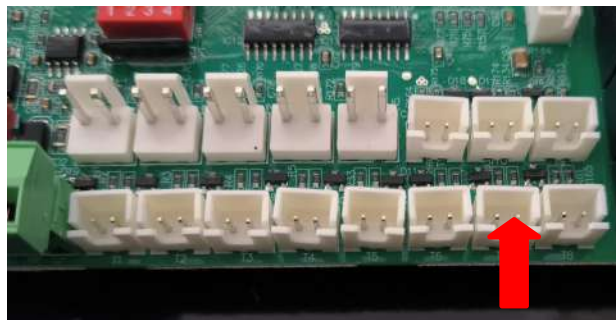

Er27
Water outlet
temperature
sensor fault



1. Check if the probe wiring is damaged;

2. Check the connection between the temperature sensor and the motherboard

3. Check the resistance value of the temperature sensor (5 K Ω). If the resistance value is too low or too high, it indicates that the sensor has a problem and needs to be replaced.

(T7 is for PW010-PW060, T3 is for PW070-PW080)

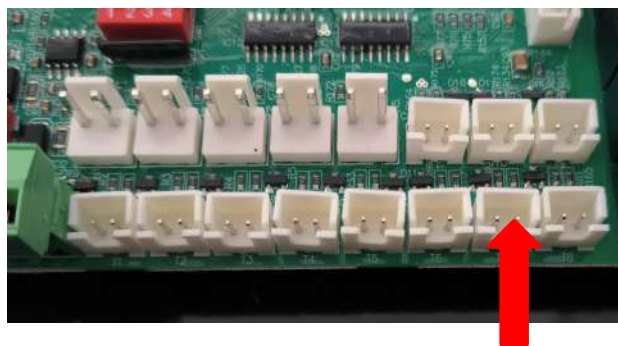

Er29
Suction gas
temperature
failure

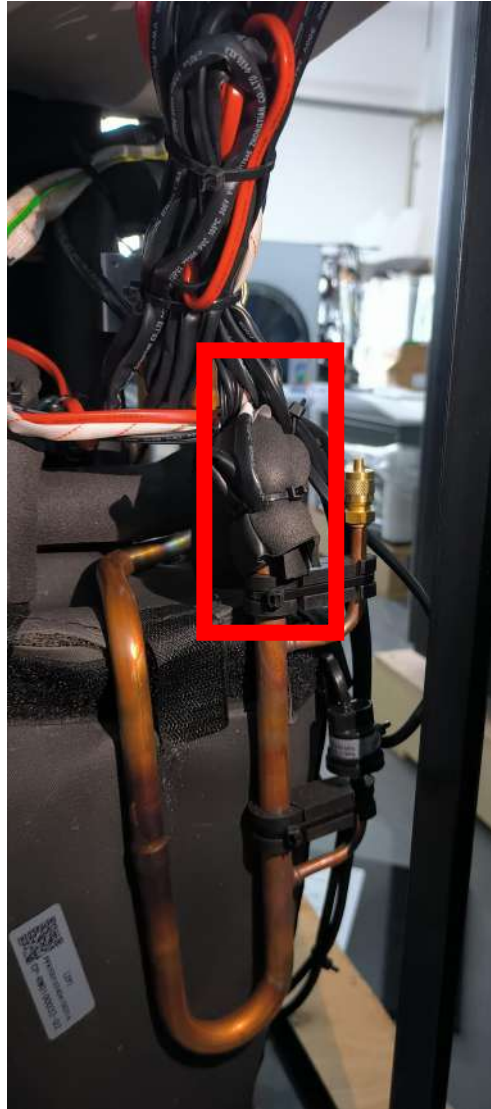

1. Check if the probe wiring is damaged

2. Check the connection between the temperature sensor and the motherboard

2. Check the resistance value of the temperature sensor ($5\text{ K}\Omega$). If the resistance value is too low or too high, it indicates that the sensor has a problem and needs to be replaced.

(T4 is for PW010-PW060, T7 is for PW070-PW080)

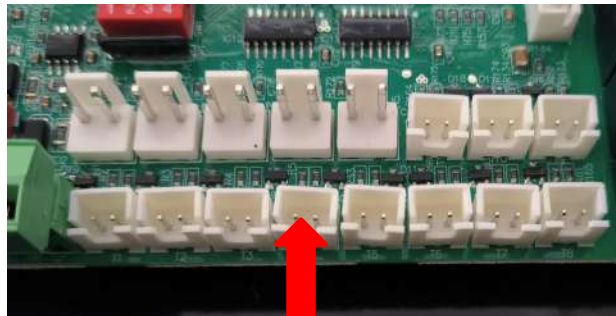

Er32
Heating water
outlet
temperature too
high protection



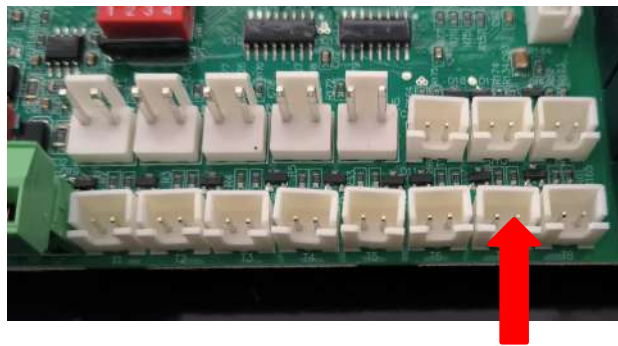

1. The outlet water temperature exceeds the system's protection threshold, low water flow rate, water pump anomaly. Check if the water valve or water pump is open.
2. The water pipeline has air or blockage, emptying and cleaning the blockage.
3. Check the inlet and outlet water temperature probe.

(T7 is for PW010-PW060, T3 is for PW070-PW080)

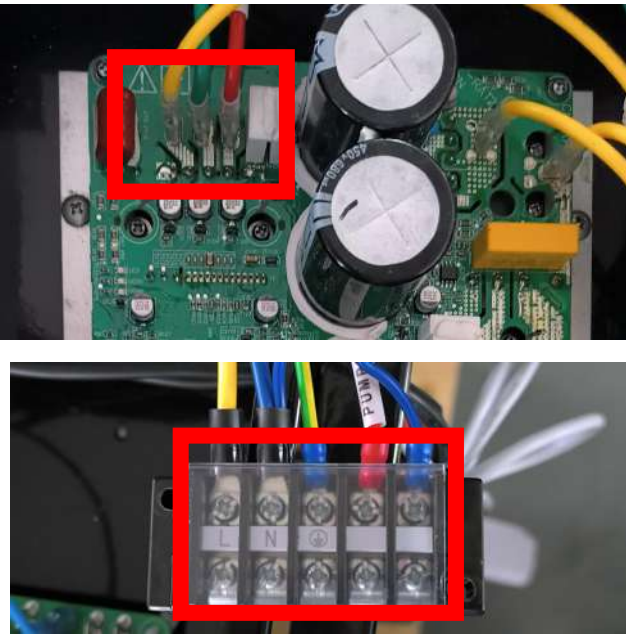
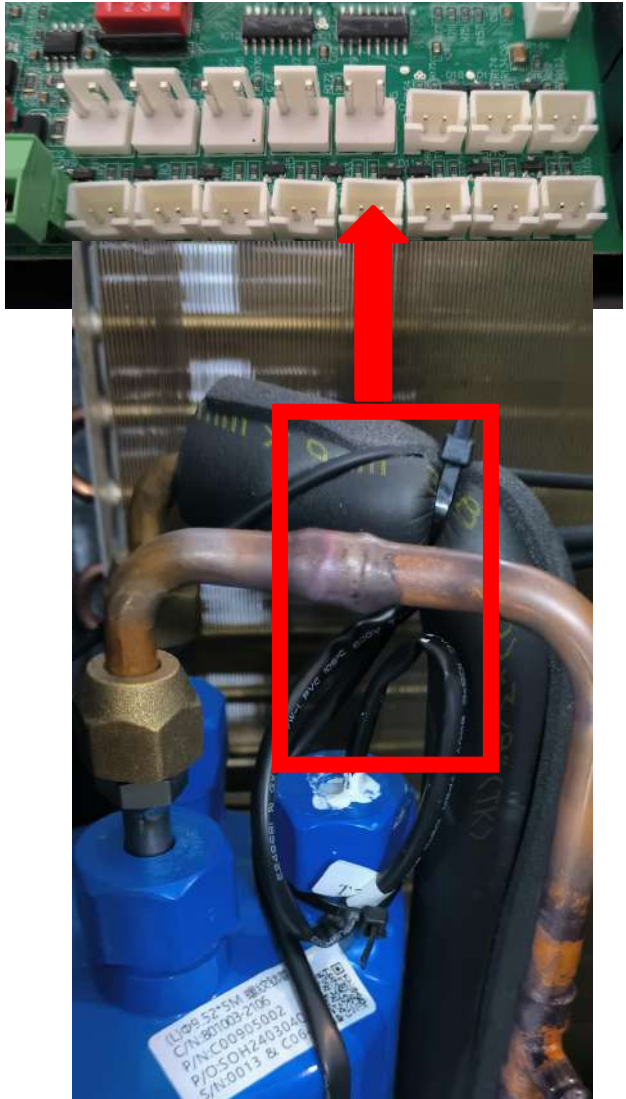

<p>Er35 Compressor current protection</p>		<ol style="list-style-type: none"> 1. Make sure the power supply voltage is within the normal operating voltage range of the machine;($\pm 10\%$) 2. Check whether the compressor works normally, check the compressor current value from the controller display screen, and measure the current of the power line with a clamp multi-meter; if the current value of the compressor does not correspond to the power line current value measured by the multi-meter, the circuit of the compressor current is damaged and needs to be replaced.
<p>Er42 Cooling coil temp. sensor failure</p>		<ol style="list-style-type: none"> 1. Check if there is any damage to the sensor and its wire; 2. Check the connection between the temperature sensor and the main board 3. Check the resistance value of the temperature sensor ($5\text{ K}\Omega$). If the resistance value is too small or too large, then the sensor has a problem and needs to be replaced. <p>(T5 is for PW010-PW060, T1 is for PW070-PW080)</p>

<p>Er74 R290 Refrigerant sensor failure</p>	 <p>R290 Detection port</p>	<p>1. Check if the probe wiring is damaged;</p> <p>3. Check the connection between the temperature sensor and the main board.</p>
<p>Er75 Refrigerant leakage protection</p>	 <p>R290 refrigerant leakage sensor</p>	<p>The refrigerant leakage sensor is used to detect and monitor the leakage of R290 refrigerant, ensuring the safety and efficiency of the system. When the leakage concentration exceeds 15% LFL, the system will sound an alarm and display fault code Er75, reminding users to handle it in a timely manner to ensure safe use.</p> <p>The compressor and all electric heating will stop, and the fan is running at the lowest speed.</p> <p>Solution: Power off the unit immediately, keep good ventilate, check the refrigerant leakage point of the unit, and repair it. (Professional installation personnel are required to operate it)</p>

9.4.2 Er20 inverter module error code troubleshooting

⚠ Safety precautions: Ensure a safe testing environment and avoid electric shock or other safety issues.

1. Fault analysis

IPM module internal fault, the possible causes of the malfunction could be as follows:

The communication wire between the driver board and the main board is damaged;

The power supply is abnormal;

The IPM driver board is faulty;

The main control board is faulty;

The compressor power line is damaged;

The compressor is faulty.....

2. Main troubleshooting

For the above reasons, please focus on checking the **main board, driver board, compressor, filter board** (PW070/080), etc. Please refer to the following inspection steps.

2.1 How to check if the main board is damaged?

① Observe whether there are black burn marks on the surface of the mainboard (power terminals, capacitors, fuses, relays, and all ports);

② Using a multi-meter to measure the L and N power ports on the mainboard to check if the voltage within a fluctuation range of $\pm 10\%$ of rated power supply?

Single phase unit: 198V-242V

Three phase unit: 342-418V

③ Check the circuit connection terminals and wiring on the mainboard to ensure that they are not loose or corroded(For single-phase PW030-060 integrated mainboard, it is also necessary to check the U V W on the mainboard). If the connector is loose or corroded, it may cause the circuit to be disconnected and needs to be reconnected or replaced.



2.2 How to check if the inverter drive module is damaged?

- ① Observe whether there are any burnt black marks on the surface of the driver board (power terminals, capacitors, fuses, reactance, and all ports)
- ② Check the circuit connection terminals and wiring on the driver board to ensure they are not loose or corroded. If the connector is loose or corroded, it may cause the circuit to be disconnected and needs to be reconnected or replaced.
- ③ Using a multi-meter to measure the power supply input ports(L N or R S T) on the main board to check if the voltage within the rated voltage fluctuation range of $\pm 10\%$ as indicated on the nameplate?
- ④ Use a multi-meter to measure whether the UVW port voltage on the driver board is normal. Too low or too high voltage will cause abnormal operation of the compressor.

Single phase unit: $311V \pm 10\%$

Three phase unit: $537V \pm 10\%$



2.3 How to check if the filter board is damaged?

- ① Observe whether there are burnt black marks on the surface of the filter board, and whether the ports and wiring are loose.
- ② Measure resistance value: Turn the knob of the multi-meter to the resistance position, touch the test pen to both ends (L N) of the filter board, and record the resistance value. If the resistance value is infinite or close to infinite, it indicates that the filter board has failed and needs to be replaced.

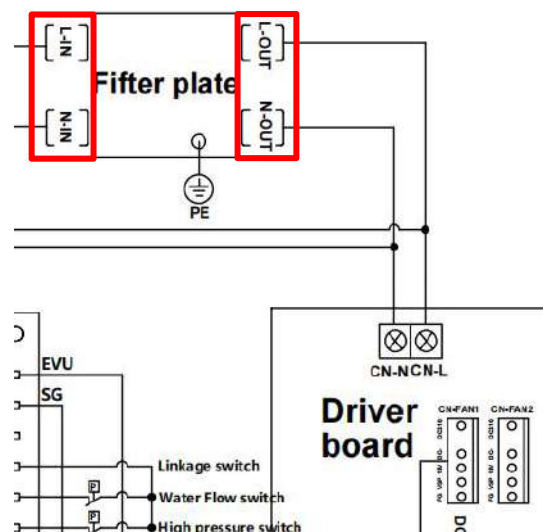

2.4 How to check if the compressor is damaged?

- ① Observe if there is any abnormal noise during the operation of the compressor? Observe if the power terminal on the top of the compressor is burnt black?
- ② Use a multi-meter to measure the U V W of the power control terminal on the top of the compressor. If the resistance values of any two terminals are close and not zero, the compressor power terminal control is normal; Then measure the resistance value of each terminal to ground, which should be above $10M\Omega$; Otherwise, it can be determined that there is an internal abnormality in the compressor and the compressor is damaged.

Step 1: Remove the top control cover of the compressor

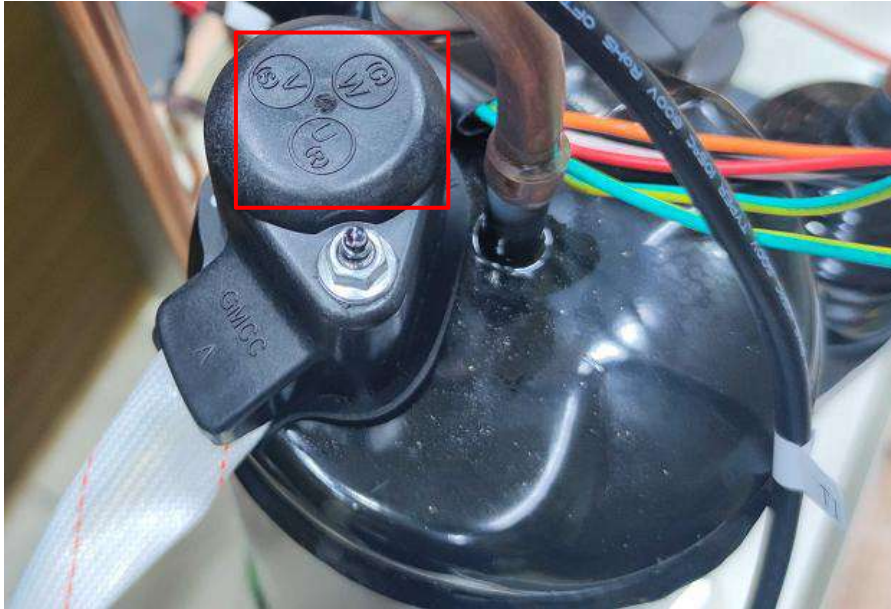

Step 2: Set the multi-meter to the Ω position and measure the resistance of U V W using method ②.

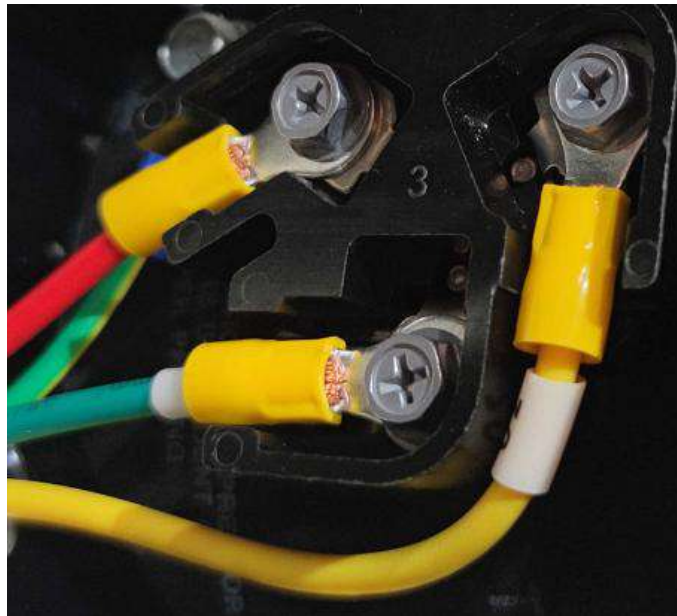

3.Detailed sub-error of Er20

For other detailed sub-error code and reasons, see the table below page.

Code	Meaning	Possible Reasons	Detecting Procedures	Solutions
1	IPM over-current	<ol style="list-style-type: none"> External overload or overheating of IPM board Short circuit of drive UVW Fault of current detection device Damage or failure of the IPM module. 	<ol style="list-style-type: none"> Check whether the machine is stuck, for example, if the compressor cylinder is stuck Check whether the feeding speed is too large Check whether if there water inside the motor power cord plug which causes short circuit Check if there is any problem with the current detection device 	<ol style="list-style-type: none"> Make sure that the machine is not stuck Appropriate feeding speed Measure the motor UVW with the multi-meter ohm gear to ensure that there is no short circuit Replace the current detection device Replace the frequency conversion module
2	The compressor or synchronization is abnormal	<ol style="list-style-type: none"> The compressor loading of the starting moment is too large The compressor does not match with the program The high and low voltage difference for starting the compressor is too large 	<ol style="list-style-type: none"> If the internal and external fan motors work normally, check whether filters of indoor equipment are full of dust Check if the air inlet of the internal and external equipment is blocked or not Check if the external main board program and the compressor match or not Check if the high and low voltage difference for start the compressor is too large or not 	<ol style="list-style-type: none"> Clean the filters Ensure that the air inlet of the internal and external machine is not blocked Replace the correct main board and use the correct program Ensure that the high and low voltage difference starts normally
8	Phase loss of the compressor or output	<ol style="list-style-type: none"> The U, V and W wires of compressor are not or not well connected The compressor and the program do not match The high and low voltage difference for start the compressor is too large Failure of phase-loss inverse protector 	<ol style="list-style-type: none"> Check if the compressor U, V and W wires are connected in a good way or not Check if the external main board program and the compressor match or not Check if the high and low voltage difference for start the compressor is too large or not Check the working status of the phase-loss inverse protector 	<ol style="list-style-type: none"> Ensure that the compressor U, V and W wires are well connected Change the correct main board or update its program Ensure that the high and low voltage difference starts normally Replace the phase-loss inverse protector
16	DC bus voltage is low	<ol style="list-style-type: none"> Power supply is not stable Mechanical failure AC suddenly power off, the DC voltage will be too low when the remaining 	<ol style="list-style-type: none"> Check whether the instantaneous voltage is too low or the power supply voltage is too low Check whether the transmission system of the motor is stuck 	<ol style="list-style-type: none"> Ensure the stable power supply Ensure that the transmission shaft system is not stuck and there is no mechanical failure Ensure that the electricity in

		electricity supports the chips of the capacitor to work 4. PFC module failure	3. Check if the DC bus low voltage is caused by remaining electricity of the capacitor or not 4. Check the PFC module for any faults	capacitor is completely discharged first and then test it again 4. Replace the faulty frequency conversion module
32	DC bus voltage is high	1. Power supply voltage is too high. When the power supply voltage exceeds the rated voltage of the converter, the output voltage of the converter will also increase, which causes high DC bus voltage. 2. Failure of the capacitor 3. Overload 4. PFC module failure	1. Check whether the power supply voltage is normal 2. Check whether the capacitor fails 3. Check whether the load of the frequency converter is too large 4. Check the PFC module for any faults	1. Ensure that the power supply voltage is normal 2. Replace the capacitor 3. Reduce load 4. Replace the faulty frequency conversion module
64	The temperature of the heat sink is too high	1. Fan motor fault 2. The air outlet duct is blocked	1. Check whether the fan motor fails 2. Check whether the air outlet duct is blocked	1. Change the fan motor 2. Ensure that the air outlet duct is clean
128	Heat sink temperature failure	1. Temperature sensor failure of short circuit or open circuit 2. Heat sink scaling 3. The ambient temperature is too high	1. Check if there is short circuit or open circuit of heat sink sensor 2. Check if there is too much dust or scaling on the heat sink 3. Check if the ambient temperature is too high.	1. Replace the frequency conversion module 2. Clean up the dust and scaling from the heat sink 3. Reduce the ambient temperature
257	Communication failure	1. The wires are not well connected 2. Internal components of the heat pump are damaged 3. The output voltage of the power board in the module is abnormal or no output	1. Check the communication wires connection between main board and frequency conversion module 2. Check whether the internal components of the heat pump are damaged 3. Check whether the power board in the module is normal	1. Reconnect the wires and ensure stability 2. Replace the internal components 3. Replace the module power board
258	Phase-locks of AC input	1. Damage of current transformer during transportation 2. The direction of the current transformer is not inserted correctly during production 3. Compressors works without any load (no air	1. Check whether the current transformer is damaged 2. Check whether the direction of current transformer is inserted correctly 3. Check AC current when compressor works without any load (no air compression) and with more than 40Hz frequency	1. Replace the good current transformer 2. Ensure that the current transformer is inserted correctly 3. Ensure that the AC current is moderate at a specific state and frequency

		compression) and with more than 40Hz, AC current is very small, leading to abnormal current transformer detection		
260	AC input over-current	<ol style="list-style-type: none"> 1.AC over-current, the load suddenly goes too large, and the frequency cannot drop in time 2. The compressor is over-power, and the load suddenly goes too large, and the frequency cannot drop in time 3. The compressor is over-power, the compressor high and low voltage difference for starting is too large 	<ol style="list-style-type: none"> 1. Test whether the load is changed suddenly 2. Check whether the high and low pressure difference of the compressor for starting is too large 	<ol style="list-style-type: none"> 1. Make sure that the load is not too high suddenly 2. Ensure that the high and low voltage difference of the compressor for starting is moderate
264	The AC input voltage is low	<ol style="list-style-type: none"> 1. The input voltage is too low 2. Current transformer is damaged during transportation 3. The direction of the current transformer is not inserted correctly during production 	<ol style="list-style-type: none"> 1. Check whether the input voltage is too low 2. Check the current transformer on the frequency converter for any damage 3. Check whether the direction of the current transformer is wrong 	<ol style="list-style-type: none"> 1. Ensure that the input voltage is normal 2. Make sure that the current transformer is not broken 3. Ensure that the current transformer is inserted correctly
272	High voltage failure	<ol style="list-style-type: none"> 1. Circulation system is blocked 2. Compressor failure, such as piston stuck or valve leakage 3. Excessive or insufficient refrigerant 4. The sensor fails 	<ol style="list-style-type: none"> 1. Check that if the refrigerant pipeline is free of impurities or ice 2. Check whether the compressor is faulty 3. Check whether the refrigerant is too much or too little 4. Check the pressure sensor or temperature sensor has failure 	<ol style="list-style-type: none"> 1. Ensure that the circulation system is not blocked 2. Replace the compressor 3. Fill or discharge it with the appropriate refrigerant 4. Replace the sensor
288	IPM temperature is too high	<ol style="list-style-type: none"> 1. Failure of fan motor or the air outlet duct is blocked 2. The ambient temperature rises too fast, resulting to the over-temperature and frequency cannot drop in time 3. Power supply voltage and current are too high or too 	<ol style="list-style-type: none"> 1. Check whether the fan motor fails, or the air duct is blocked 2. Check whether the ambient temperature rises up too fast 3. Check whether the power supply voltage and current is too high or too low 	<ol style="list-style-type: none"> 1. Replace the fan motor, or ensure that the air outlet duct is clear 2. Reduce ambient temperature 3. Ensure that the power supply voltage and current is normal

		low		
320	Compress or peak current is too high	1. Current of compressors wires is too large 2. The drive program and compressor do not match	1. Check whether the current of compressor wires is too large 2. Check whether the main board driver program matches with the compressor	1. Ensure that current of the compressor wires is appropriate 2. Update the program to ensure it matches with the compressor 3. Replace the frequency conversion module
384	PFC module over-temperature protection	Reserved only for old 2.0kw and 4.5kw boards	1. Poor heat dissipation, condensing fan speed is too low or stops running unexpectedly 2. The ambient temperature rises too quickly, causing over temperature and frequency reduction to fail to react in time	1. Replace the fan 2. Ensure that the air duct unblocked 3. Reduce the ring temperature 4. Ensure that the power supply voltage and current are normal

9.4.3 Common faults and debugging

If users have any problems in the process of work, they must hire professional maintenance personnel for maintenance. Maintenance personnel may refer to the chart for debugging.

Malfunctions	Observation	Reasons	Solution
Heat pump is not running	Wired controller shows no display	No power supply	Check whether cable and circuit breaker are connected
	Wired controller displays the actual time	Heat pump under standby status	Startup heat pump to run.
	Wired controller displays the actual water temperature	1. Water temperature is reaching set value, heat pump under constant temperature status 2. Heat pump just starts to run 3. Under defrosting	1. Verify water temperature setting 2. Startup heat pump after a few minutes 3. LED wire controller should display "Defrosting"
Water temperature is cooling when heat pump runs under heating mode	Wired controller displays actual water temperature and no error code displays	1. Chose the wrong mode 2. Figures show defects 3. Controller defect	1. Adjust the mode 2. Replace the defect LED wire controller, and then check the status after changing the running mode, verifying the water inlet and outlet temperature 3. Replace or repair the heat pump

Short running	Wired displays actual water temperature, no error code displays	<ol style="list-style-type: none"> 1. Fan NOT running 2. Not enough air ventilation 3. Not enough refrigerant 	<ol style="list-style-type: none"> 1. Check the cable connections between the motor and fan, if necessary, they should be replaced 2. Check the location of the heat pump, and eliminate all obstacles to assure a good air ventilation 3. Replace or repair the heat pump
water stains	Water stains on heat pump unit	<ol style="list-style-type: none"> 1. Concreting 2. Water leakage 	<ol style="list-style-type: none"> 1. No action 2. Check the titanium heat exchanger carefully if it shows any defects
Too much ice on evaporator	Too much ice on evaporator		<ol style="list-style-type: none"> 1. Check the location of heat pump, and eliminate all obstacles to assure a good air ventilation 2. Replace or repair the heat pump

10.WIFI Connection and Operation

10.1 APP Download

Please go to “Google Play Store” or “Apple App Store” and search “Smart Life”, then download. See below figures.

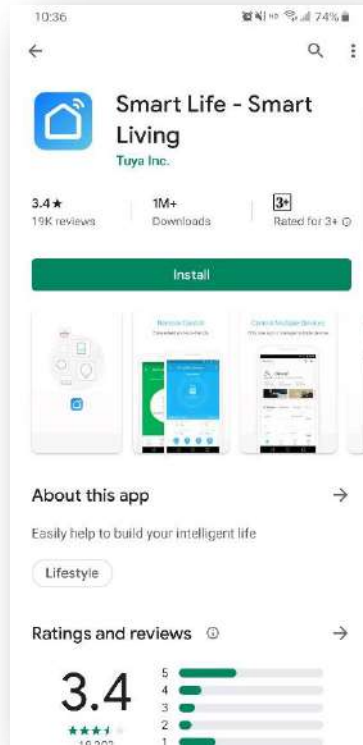

10.2 Registration&Login

10.2.1 Registration

If you do not have app account, you may choose to register or Log in by authorization code.

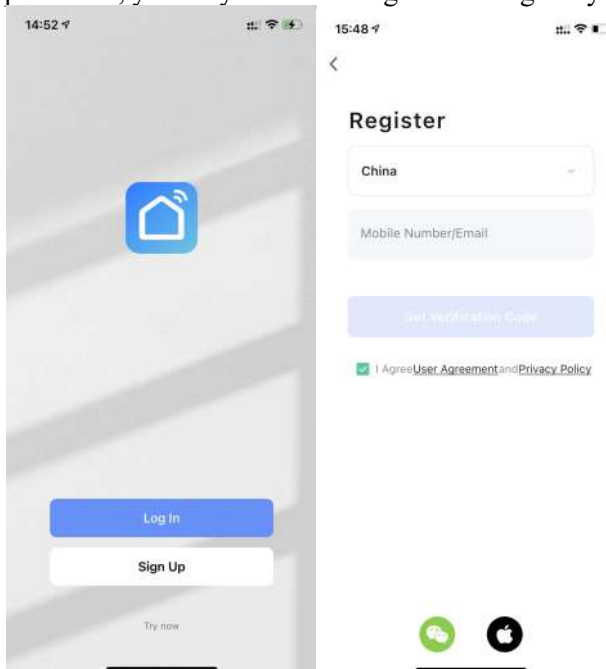

10.2.2 Login



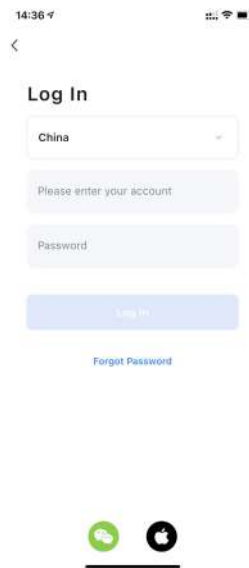



If you already have an app account, please click "Log in" to enter the login page. Enter your registered mobile phone number or email, enter the password in to log in





11.3 WIFI network configuration steps

1) Step 1:

Solution 1: When powering on, the interface of the wire controller will flash "" to enter the intelligent network connection. At this time, the network can be carried out. If there has been no pairing, the network will be exited and the intelligent network connection mode needs to be entered manually:

Press and hold the "  " and "  " keys for 5 seconds to enter the pairing state. The "  " icon in the upper left corner flashes quickly. After successful pairing, the icon stays on. If pairing is unsuccessful or has not been paired, the icon will not be displayed after 3 minutes, and the network configuration state will be exited. The "  " icon stops flashing, and the WIFI module will no longer be paired. To re-pair, press and hold the "  " and "  " keys for 5 seconds;

Solution 2: Press and hold the "  " and "  " keys for 3 seconds to enter the "Compatibility Mode" network configuration. The "  " icon flashes slowly when entering.

2) Step 2: Turn on the Bluetooth and WIFI functions of your phone and connect to the WIFI hotspot. The WIFI hotspot must be able to connect to the Internet normally, as shown in the figure: Connect to the WIFI hotspot "pwwm;

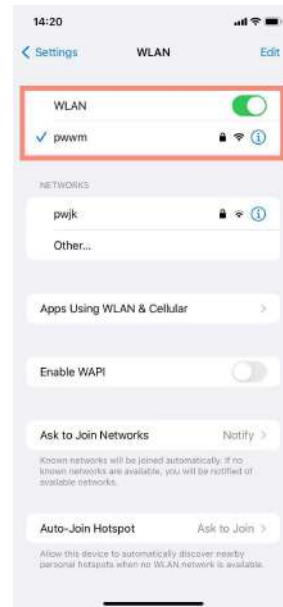
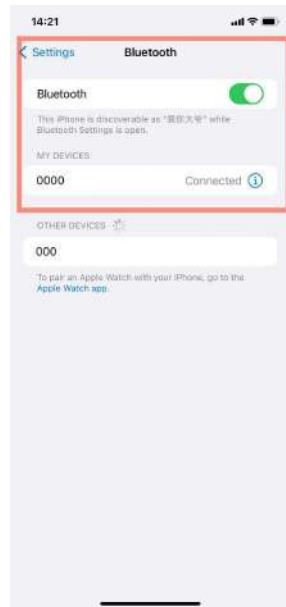

3)Step 3:

Add device solution 1:

Open the "Smart Life" APP, log in to the main interface, click "Add Device" and select " Add " → enter WiFi information → Complete;

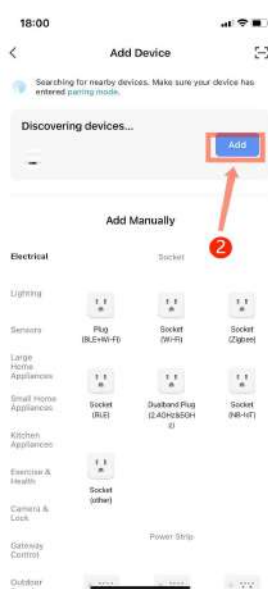
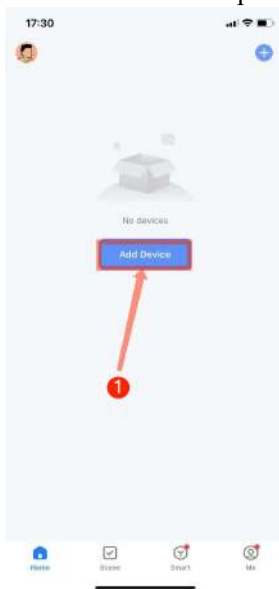

Add device solution 2:

Open the "Smart Life" APP, log in to the main interface, click "+" in the upper right corner, enter the device type selection, select " Large Appliances " → Select " Water Heater " → Enter WiFi information → Complete ;

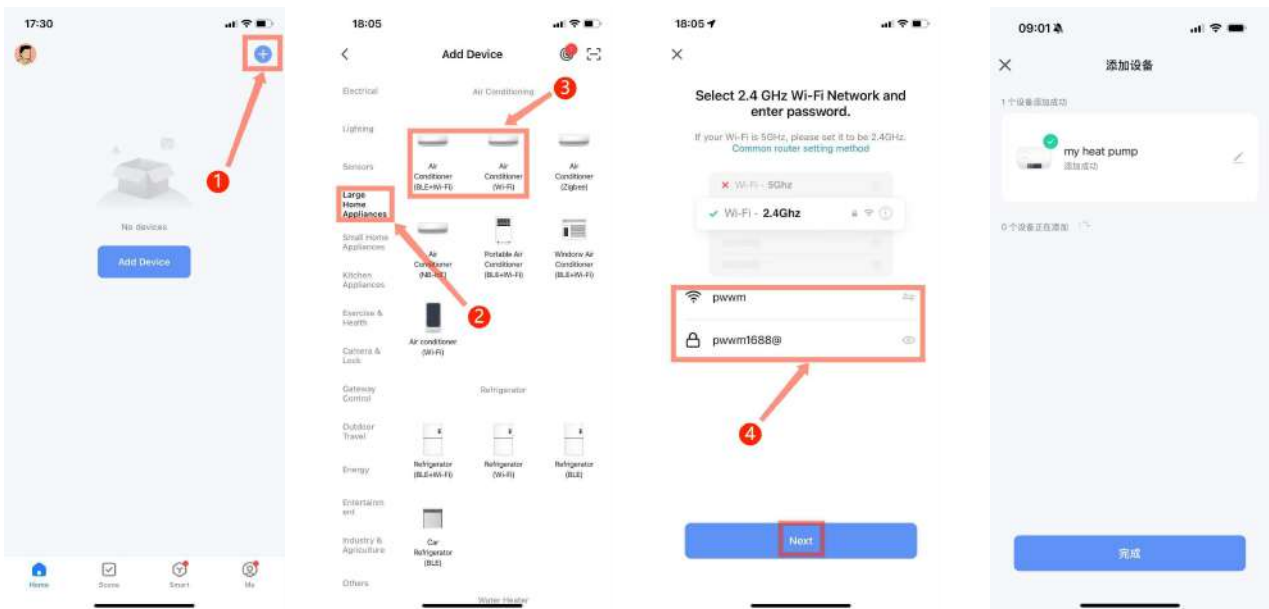

10.4 Functional Operation

1) After the device is successfully bound, click on the "my heat pump" (device name, editable) operation page on the "Smart Life" main interface.

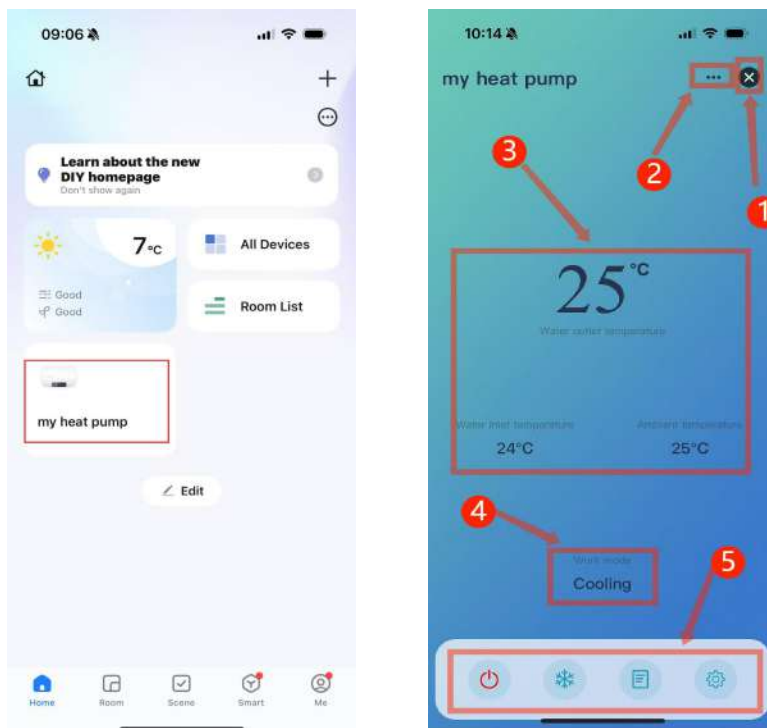

①-Return: Return to the main page;

②-More: You can change the device name, select the device installation location, check the network status, add shared users, create a device group, view device information, etc.;

③-Temperature: water outlet temperature, water inlet temperature, ambient temperature;

④-Current mode;

⑤-Power on/off settings, operation mode, parameter status, settings

2) Modify the device name:

Click " More " in the order shown below to enter "Device Details" and click "Device Name" to rename the device.

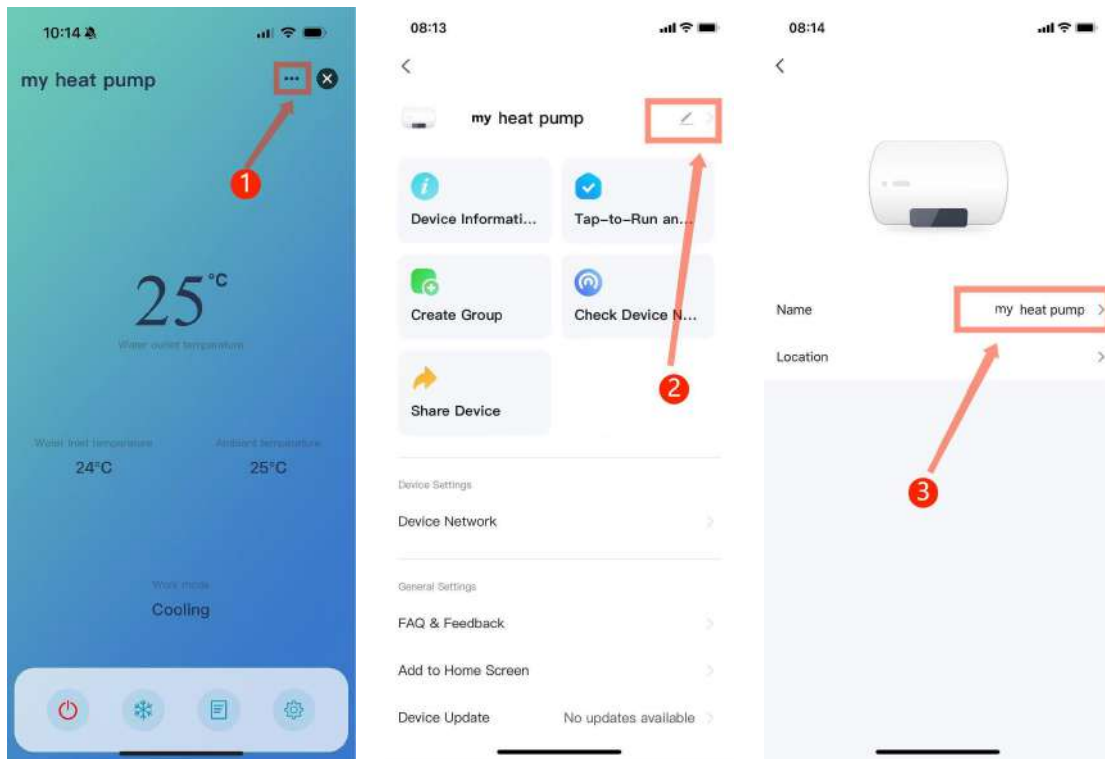

3) Device Sharing

To share a bound device, the sharer follows the following steps: click "More" → "Shared Device" → "Add" → enter the account of the person to be shared with, click "Finish", and the newly added account of the person to be shared will be displayed in the list of successful sharing ;

If you need to delete the person you are sharing with, long press the selected user, the deletion interface will pop up, click "Delete" ;

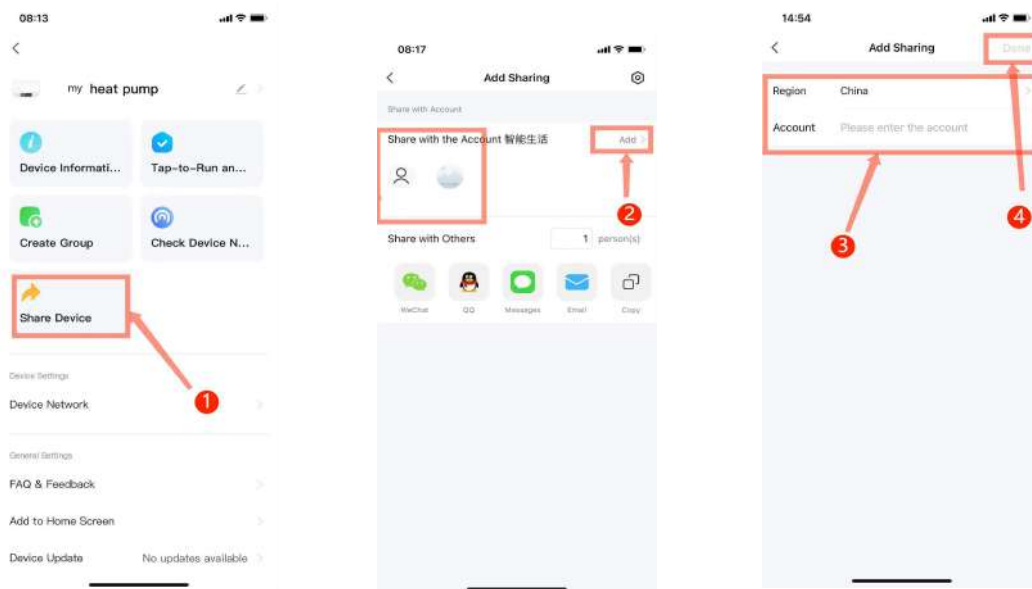

4) Device Sharing

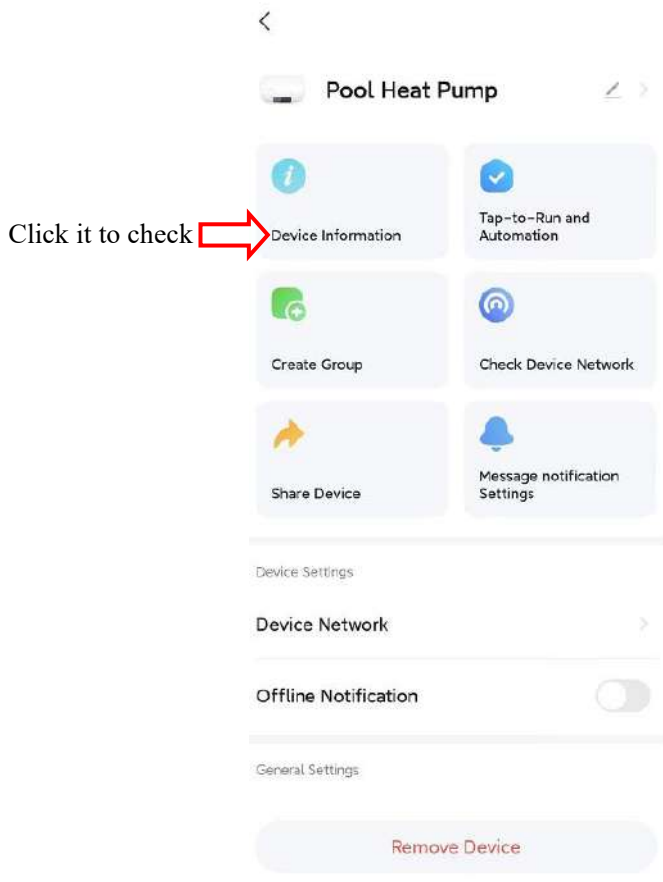

10.5 Mode Settings

When the device is powered on, click "  " on the main interface to switch modes. The mode selection interface will pop up as shown below. Click the mode you want to select.

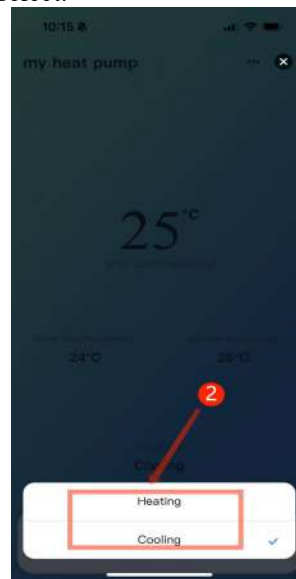

10.6 Timing Settings



Click "  " on the main interface of the device operation to enter the "Settings" menu, find "Schedule" to enter the schedule setting interface, select "Add" → adjust "Clock" → "Minutes" according to the situation → Select the days to execute → Execute notification → Select "Turn on" or "Turn off" as shown below, and click Add Schedule;

If you want to delete a timer, press and hold the timer item and swipe left to pop up the "Delete" icon. Click it to

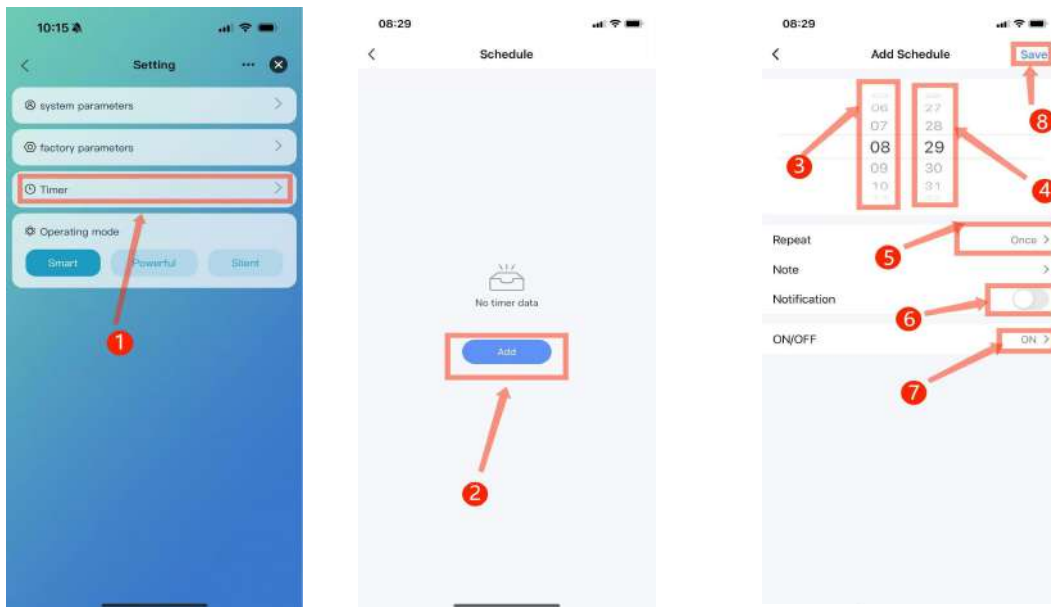
delete.



10.7 Device Removal

On the main interface, click "  " in the upper right corner to enter the device details interface. Click "Remove Device" at the bottom of the device details interface, and the wired controller will enter the intelligent network configuration mode. The "  " icon will not flash, and the network configuration can be re-established within 3 minutes. If more than 3 minutes pass, the network configuration will be exited. The specific operations are as shown in the following sequence;

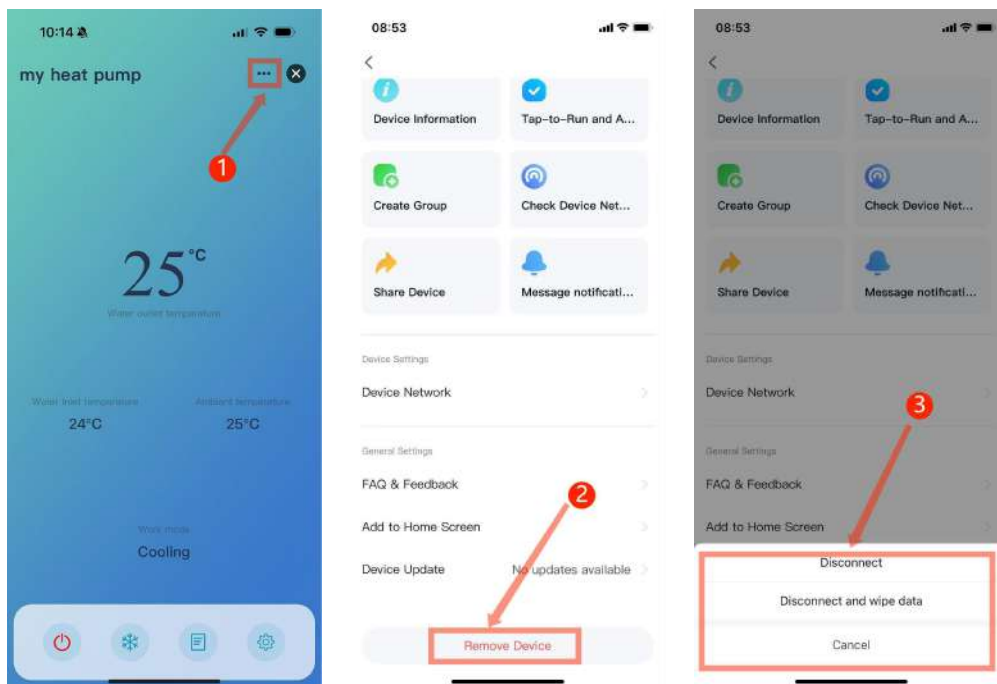

10.8 Status parameters

Click on State to view basic state parameters such as inlet and outlet water temperature, exhaust opening, etc.



10.9 Water temperature setting

In the settings interface, click on "System Parameters" to set the desired temperature, temperature difference, and temperature scale switching.

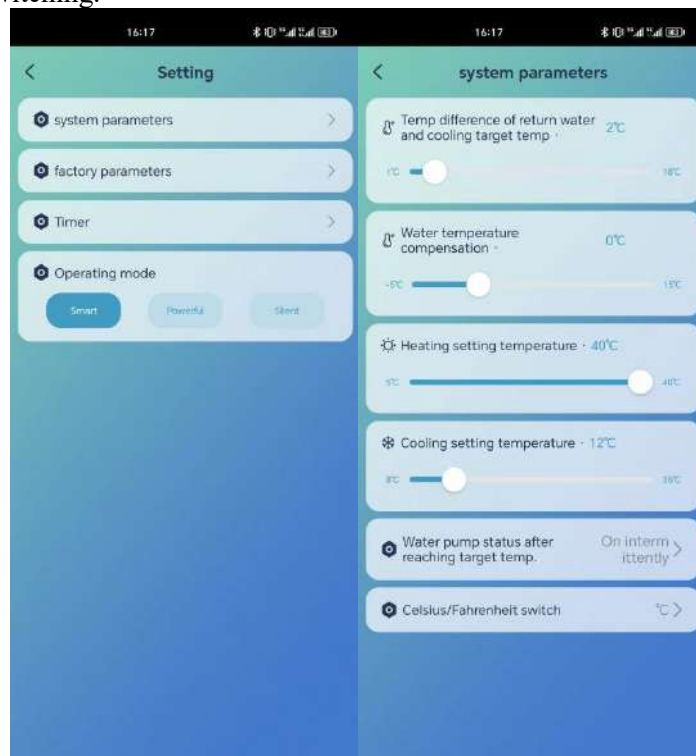

Appendix

A. Commissioning Checklist

Installer name				Install engineer/Telephone						
User's basic information		Name/Telephone								
		Install address								
		Area	m	Building insulation						
		User's end device	Radiator <input type="checkbox"/>	Floor heating <input type="checkbox"/>	Fan coil <input type="checkbox"/>	Domestic hot water <input type="checkbox"/>	Swimming pool heat pump <input type="checkbox"/>		Others <input type="checkbox"/>	Remarks:
		Actual input voltage			V	Actual water pressure				MPa
Heat pump model/Input power						Heat pump pressure gauge value	MPa			
Heat pump install position	Outdoor <input type="checkbox"/>	In the yard <input type="checkbox"/>	Rooftop <input type="checkbox"/>	Wall split <input type="checkbox"/>	Others <input type="checkbox"/>	Install base bracket	Concrete <input type="checkbox"/>	Steel structure <input type="checkbox"/>	Rubber Shock Pad <input type="checkbox"/>	
Heat pump installation and commissioning steps										
1	Measure the user's power supply voltage with a multi-meter, check the tap water pressure, and check if the installation position is appropriate;(Water pressure of tap water $\geq 0.2\text{MPa}$, $0.25\sim 0.4\text{MPa}$ is normal)					Conclusion		Qualified <input type="checkbox"/>	Abnormal:	
2	Wear gloves and unpack to inspect the appearance of the heat pump for any damage; If the heat pump has a pressure gauge, check the pressure value((With the ambient temp $10\sim 25^{\circ}\text{C}$, the normal Static pressure within $0.6\text{-}1.0\text{MPa}$);					Conclusion		Qualified <input type="checkbox"/>	Abnormal:	
3	Install the heat pump on a solid foundation, install shock rubber pads to fix the device, fix the balance water tank, install the chloride ion disinfection device and filtration device and reserve the installation position of the water pump and valves; Reserve heat pump floor drainage; Reserve the position of the heat pump power supply port;					Conclusion		Qualified <input type="checkbox"/>	Abnormal:	
4	According to the installation diagram, check the connection of pipeline joints for accessories such as heat pumps, all ball valves, check valves, filters, and water pumps; Determine whether the installation direction of the water pump, and valve components is correct;					Conclusion		Qualified <input type="checkbox"/>	Abnormal:	
5	According to the installation diagram, check if the installed pipeline accessories are correct, conduct water pressure and leakage testing, exhaust the water pump and system; (Water pressure of tap water $\geq 0.2\text{MPa}$);					Conclusion		Qualified <input type="checkbox"/>	Abnormal:	
6	According to the wiring diagram of the heat pump, connect the power wires of the heat pump, install the operation panel, connect the power wire of the water pump, and other necessary circuits to connect the heat pump;					Conclusion		Qualified <input type="checkbox"/>	Abnormal:	
7	According to the wiring diagram of the heat pump, check whether the power cord is tightened, whether the sensor position is correct, and whether the wiring position is fixed to ensure the protection of the circuit;					Conclusion		Qualified <input type="checkbox"/>	Abnormal:	

8	After the above checks are normal, open all water valves; Power on inspection, first use a multi-meter to check if the power supply voltage is normal (The voltage fluctuation range of the inverter unit is $\pm 10\%$);	Conclusion	Qualified <input type="checkbox"/> Abnormal:
9	According to the instructions in the manual, use the operation panel to start up and run, check the operation of the water pump, and recheck whether there is any water leakage problem in the pipeline; No water leakage, insulation should be applied to all pipelines;	Conclusion	Qualified <input type="checkbox"/> Abnormal:
10	Check if the drainage of the heat pump chassis is reasonable and smooth without water accumulation (if the weather is dry and does not produce condensation, tap water can be used to simulate the drainage situation);	Conclusion	Qualified <input type="checkbox"/> Abnormal:
11	According to the heat pump manual, check the temperature status and pressure gauge values of the heat pump after ten minutes of normal operation; Checking if the water outlet temp, water inlet temp, exhaust temp, high pressure and the voltage are reasonable.	Conclusion	Qualified <input type="checkbox"/> Abnormal:
12	After installation and commissioning, the customer can operate the heat pump control panel according to the instructions, such as adjusting the temperature, checking the temperature status of the heat pump, daily maintenance and protection of the heat pump, and regular maintenance and inspection.	Conclusion	Qualified <input type="checkbox"/> Abnormal:
Installation engineer's master rechecks and confirms/notes			
User's confirmation		Date	

B. Temperature sensor resistance with different ambient temp.

2.1 5K Sensor Resistance(T2-T7 for PW010-PW060, T1-T5&T7 for PW070-PW080)

Temp(°C)	Resistance(KΩ)	Temp(°C)	Resistance(KΩ)	Temp(°C)	Resistance(KΩ)
-30	63.7306	14	7.7643	58	1.5636
-29	60.3223	15	7.4506	59	1.5142
-28	57.1180	16	7.1813	60	1.4856
-27	54.1043	17	6.8658	61	1.4206
-26	51.2686	18	6.5934	62	1.3763
-25	48.5994	19	6.3333	63	1.3336
-24	46.0860	20	6.0850	64	1.2923
-23	43.7182	21	5.8479	65	1.2526
-22	41.4868	22	5.6213	66	1.2142
-21	39.3833	23	5.4048	67	1.1771
-20	37.3992	24	5.1978	68	1.1413
-19	35.5274	25	5.0000	69	1.1008
-18	33.7607	26	4.8108	70	1.0734
-17	32.0927	27	4.6298	71	1.0412
-16	30.5172	28	4.4586	72	1.0100
-15	29.0286	29	4.2909	73	0.9800
-14	27.6216	30	4.1323	74	0.9508
-13	26.2913	31	3.9804	75	0.9228
-12	25.0330	32	3.8349	76	0.8957
-11	23.8424	33	3.6955	77	0.8695
-10	22.7155	34	3.5620	78	0.8441
-9	21.6486	35	3.4340	79	0.8196
-8	20.6380	36	3.3119	80	0.7959
-7	19.6806	37	3.1937	81	0.7730
-6	18.7732	38	3.0809	82	0.7508
-5	17.9129	39	2.9727	83	0.7295
-4	17.0970	40	2.8688	84	0.7086
-3	16.3230	41	2.7692	85	0.6885
-2	15.5886	42	2.6735	86	0.6690
-1	14.8713	43	2.5816	87	0.6502
0	14.2293	44	2.4936	88	0.6320
1	13.6017	45	2.4097	89	0.6144
2	13.0057	46	2.3276	90	0.5973
3	12.4390	47	2.2491	91	0.5808
4	11.9011	48	2.1739	92	0.5647
5	11.3894	49	2.1016	93	0.5492
6	10.9028	50	2.0321	94	0.5342
7	10.4399	51	1.9656	95	0.5196
8	9.9995	52	1.9016	96	0.5088
9	9.5802	53	1.8399	97	0.4919

10	9.1810	54	1.7804	98	0.4786
11	8.8008	55	1.7232	99	0.4650
12	8.4395	56	1.6680	100	0.4533
13	8.0934	57	1.6140		

2.2 50K Sensor Resistance(T1 Exhaust gas temp for PW010-PW060, T6 for PW070-PW080)

Temp(°C)	Resistance (KΩ)	Temp(°C)	Resistance (KΩ)	Temp(°C)	Resistance (KΩ)	Temp(°C)	Resistance (KΩ)
-30	866.96	12	90.426	54	15.41	96	3.7351
-29	815.7	13	86.262	55	14.844	97	3.6238
-28	767.71	14	82.312	56	14.302	98	3.5162
-27	722.87	15	78.561	57	13.782	99	3.4123
-26	680.87	16	75.001	58	13.284	100	3.312
-25	641.59	17	71.625	59	12.807	101	3.215
-24	604.82	18	68.416	60	12.348	102	3.1214
-23	570.34	19	65.368	61	11.909	103	3.031
-22	538.03	20	62.474	62	11.487	104	2.9435
-21	507.74	21	59.719	63	11.083	105	2.8589
-20	479.34	22	57.104	64	10.694	106	2.7772
-19	452.68	23	54.62	65	10.321	107	2.6982
-18	427.67	24	52.253	66	9.9628	108	2.6218
-17	404.17	25	50	67	9.6187	109	2.5479
-16	382.11	26	47.857	68	9.2882	110	2.4764
-15	361.35	27	45.817	69	8.9706	111	2.4072
-14	341.86	28	43.877	70	8.6655	112	2.3403
-13	323.53	29	42.027	71	8.3723	113	2.2755
-12	306.29	30	40.265	72	8.0903	114	2.2128
-11	290.06	31	38.585	73	7.8193	115	2.1522
-10	274.78	32	36.987	74	7.5586	116	2.0934
-9	260.4	33	35.462	75	7.3077	117	2.0365
-8	246.85	34	34.007	76	7.0667	118	1.9814
-7	234.08	35	32.619	77	6.8345	119	1.928
-6	222.02	36	31.297	78	6.6109	120	1.8764
-5	210.69	37	30.034	79	6.396	121	1.8263
-4	199.98	38	28.827	80	6.189	122	1.7778
-3	189.86	39	27.677	81	5.9894	123	1.7308
-2	180.34	40	26.578	82	5.7976	124	1.6852
-1	171.33	41	25.528	83	5.6126	125	1.6411
0	162.81	42	24.524	84	5.4346	126	1.5983
1	154.78	43	23.566	85	5.2629	127	1.5567
2	147.19	44	22.648	86	5.0974	128	1.5165
3	140	45	21.773	87	4.9379	129	1.4774
4	133.21	46	20.935	88	4.7842	130	1.4396
5	126.79	47	20.134	89	4.6359	131	1.4028
6	120.72	48	19.368	90	4.4931	132	1.3672
7	114.96	49	18.635	91	4.3552	133	1.3327
8	109.51	50	17.932	92	4.2222	134	1.2991
9	104.34	51	17.26	93	4.0939	135	1.2665
10	99.456	52	16.616	94	3.97	136	1.2349
11	94.826	53	16.001	95	3.8506	137	1.2042

Temp(°C)	Resistance(KΩ)	Temp(°C)	Resistance(KΩ)	Temp(°C)	Resistance(KΩ)
138	1.1744	180	0.4496	222	0.2004
139	1.1455	181	0.4403	223	0.1969
140	1.1174	182	0.4313	224	0.1934
141	1.0901	183	0.4225	225	0.1901
142	1.0636	184	0.4138	226	0.1868
143	1.0379	185	0.4054	227	0.1836
144	1.0128	186	0.3972	228	0.1804
145	0.9886	187	0.3892	229	0.1773
146	0.9649	188	0.3814	230	0.1743
147	0.942	189	0.3738	231	0.1713
148	0.9197	190	0.3664	232	0.1684
149	0.898	191	0.3591	233	0.1656
150	0.8769	192	0.352	234	0.1628
151	0.8564	193	0.3451	235	0.1601
152	0.8364	194	0.3383	236	0.1574
153	0.817	195	0.3317	237	0.1548
154	0.7982	196	0.3253	238	0.1522
155	0.7798	197	0.319	239	0.1497
156	0.762	198	0.3128	240	0.1472
157	0.7446	199	0.3068	241	0.1448
158	0.7277	200	0.3009	242	0.1425
159	0.7112	201	0.2952	243	0.1401
160	0.6952	202	0.2896	244	0.1379
161	0.6796	203	0.2841	245	0.1356
162	0.6645	204	0.2787	246	0.1335
163	0.6497	205	0.2735	247	0.1313
164	0.6353	206	0.2684	248	0.1292
165	0.6213	207	0.2634	249	0.1272
166	0.6077	208	0.2585	250	0.1252
167	0.5944	209	0.2537		
168	0.5814	210	0.2491		
169	0.5688	211	0.2445		
170	0.5566	212	0.24		
171	0.5446	213	0.2357		
172	0.5329	214	0.2314		
173	0.5216	215	0.2272		
174	0.5105	216	0.2231		
175	0.4997	217	0.2191		
176	0.4892	218	0.2152		
177	0.4789	219	0.2114		
178	0.4689	220	0.2076		
179	0.4591	221	0.204		