

Fan Coil Unit

Operation and Installation Manual



**Wall Mounted Fan Coil
FC02, 03, 04, 05, 06, 08**

*Please read this manual before using the fan coil.

*Please keep this manual for future use

Table of Contents

| | |
|---|----|
| 1. Safety and User Information | 02 |
| 2. Product Introduction..... | 04 |
| 3. Installation..... | 10 |
| 4. Commissioning | 14 |
| 5. Maintenance and Troubleshooting..... | 16 |

Note:

All illustrations and contents in this manual are provided for information only. We will continuously improve the products in aspects of product dimensions, performances, materials and structures without prior notification.

1. Safety and User Information

1.1 Safety instructions

The Wall Mounted fan coil units are developed and manufactured in accordance with the state-of-the-art technological standards and established technical safety norms and regulations. The Wall Mounted fan coil units comply with the Machinery Safety Directive.

The Wall Mounted fan coil units are reliable and satisfy high quality standards. This product range combines advanced technology with a high level of user friendliness and ease of maintenance.

However, all fan coil units inevitably pose residual risks of injury to the user or third parties or material damage to the unit or other objects. For this reason, you should take into account and follow all safety instructions. Ignoring these safety instructions is connected with risks to your health and safety, can lead to the environmental damage and/or extensive material damage.

Observing the safety instructions in the operation manual will help you to avoid risks, ensure economical operation of the unit and enjoy full benefits of the product.

The safety aspects covered by this Chapter are valid for the entire operation manual. To ensure our own safety consider the following safety instructions.

ELECTRICAL HAZARD!

Before carrying out any work on the unit, power the unit down to avoid injury from electrical current. Check that the unit is isolated and ensure that the appropriate point of the unit for the on-site power supply is secured against being switched back on.

DANGER OF SCALDING!

Before performing work on the valves or the inlet or outlet pipes, seal off the heating or cooling medium inlet to prevent scalding. Do not commence work before the heating medium has cooled down.

DANGER OF ROTATING UNIT PARTS!

Rotating fan wheels can cause injury! Before performing any work on the unit, ensure that it is powered down. Ensure that the appropriate point of the unit for the on-site power supply is secured against being switched back on.

DANGER OF OVER HEAD LOADS!

Wear a helmet and safety boots to prevent injury from falling components, especially when fitting the unit to the ceiling. Ceiling installations should always be performed by two people.

PERSONAL INJURY!

Always wear protective gloves when moving or fitting the unit to avoid injury from sharp edges.

1.2 Important notes

The fan coil units are end units of chilled/hot water air conditioning system featuring high profession and high technological requirement, therefore, the unit shall be installed, operated and maintained only by qualified, specially trained and authorized staff.

1.2.1 Proper use

Wall Mounted fan coil units are exclusively designed for ventilating, heating, filtering and cooling purposes. Chilled water/Hot water may be used as the medium. The following limit values apply to the medium for operating Cu/Al heat exchangers:

| | | Unit | Value |
|-------------------------|-------------------------------------|-------|----------------|
| pH value (at 20 °C) | | | 7,5 – 9 |
| Conductivity (at 20 °C) | | µS/cm | < 700 |
| Oxygen content | O ₂ | mg/l | < 0,1 |
| Total hardness | | °dH | 1 – 15 |
| Dissolved Sulphur | S | | not detectable |
| Sodium | Na ⁺ | mg/l | < 100 |
| Iron | Fe ²⁺ , Fe ³⁺ | mg/l | < 0,1 |
| Manganese | Mn ²⁺ | mg/l | < 0,05 |
| Ammonium content | NH ₄ ⁺ | mg/l | < 0,1 |
| Chloride | Cl ⁻ | mg/l | < 100 |
| Sulphate | SO ₄ | mg/l | < 50 |
| Nitrite | NO ₂ | mg/l | < 50 |
| Nitrate | NO ₃ | mg/l | < 50 |

DAMAGE TO THE UNIT!

On open systems (e.g. when using well water observe the limit values stated in above table), the used water should additionally be cleansed of suspended matter using a filter which should be located at the inlet. Otherwise there is a risk of erosion by suspended matter.

You also have to ensure that the unit is protected from dust and other substances that can cause acidic or alkaline reaction when combined with water (aluminum corrosion).

— The Wall Mounted fan coil units may only be used indoors.

— The Wall Mounted fan coil units is suitable for wall mounted installation.

The unit is considered to be used in an improper manner if it is applied for other purposes or a purpose that is not covered by the scope of the given operation manual. The manufacturer or supplier is not liable for any resulting damage: the user alone bears the full risk.

The user is responsible for proper use. Proper use also stipulates the observance of the operation manual and the inspection and maintenance conditions defined by the manufactures.

1.2.2 Improper use

The Wall Mounted fan coil may not be operated:

- In locations where there is a risk of explosion
- In wet areas or
- In locations with high dust levels or aggressive air.

PERSONAL INJURY & MATERIAL DAMAGE!

Improper use can cause personal injury and material damage.

2. Product Introduction

2.1 Features and benefits

Wall Mounted fan coil units have become a hall mark for de-central air treatment, with top levels of comfort and truly impressive cost-effectiveness. A selection of versatile fan coil units assures that we offer you the perfectly matching product solution for each of your individual requirements.

Effectiveness

Wall Mounted fan coil units guarantee cozy and comfortable room atmosphere.

Quietness

Sophisticated systems mean that Wall Mounted fan coil units are characterize by a minimum of noise emission.

Stylishness

The modern appealing design of Wall Mounted fan coil units is truly impressive.

Cost effectiveness

Wall Mounted fan coil units have become the effective standard solution in many and various industrial segments for comfortable economical air conditioning.

Profitability

Wall Mounted fan coil units operate with low maintenance and follow-up costs.

2.2 Nomenclature

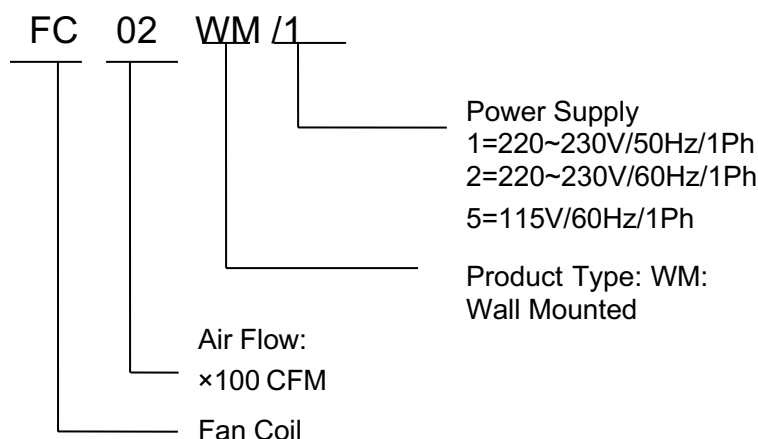

2.3 Operating limits

| Unit and heat exchanger | Values |
|--------------------------------------|--|
| Max. operating pressure/temperature | 1,6 MPa (16 bar) / 85 °C |
| Max. permissible ambient temperature | 40 °C |
| Min. permissible ambient temperature | 2 °C |
| Operating voltage | 220~230V AC (50Hz or 60Hz) *[Refer to nameplate] |
| Power consumption/protection class | *[Refer to nameplate] |

DAMAGE TO THE UNIT!

Please refer to unit name plate to know the right power supply! Wrong power supply may damage the motor and unit permanently!

2.4 Specifications

| Specification | Model | | FC02 | FC03 | FC04 | FC05 | FC06 | FC08 |
|------------------------------|------------------------|-------------------|--|------|-------------|------|--------------|-------|
| Air Flow | H | CFM | 200 | 300 | 400 | 500 | 600 | 800 |
| | | m ³ /h | 340 | 510 | 680 | 850 | 1020 | 1360 |
| | M | CFM | 153 | 224 | 303 | 382 | 450 | 594 |
| | | m ³ /h | 260 | 380 | 515 | 650 | 765 | 1010 |
| | L | CFM | 106 | 153 | 200 | 253 | 306 | 412 |
| | | m ³ /h | 180 | 260 | 340 | 430 | 520 | 700 |
| Total Cooling Capacity kW | H | | 1.80 | 2.70 | 3.60 | 4.50 | 5.40 | 7.20 |
| | M | | 1.48 | 2.21 | 2.95 | 3.69 | 4.43 | 5.90 |
| | L | | 1.10 | 1.65 | 2.20 | 2.75 | 3.29 | 4.39 |
| Sensible Cooling Capacity kW | H | | 1.40 | 2.11 | 2.81 | 3.51 | 4.21 | 5.62 |
| | M | | 1.12 | 1.68 | 2.25 | 2.81 | 3.37 | 4.49 |
| | L | | 0.90 | 1.35 | 1.80 | 2.25 | 2.70 | 3.59 |
| Heating Capacity kW | H | | 2.70 | 4.50 | 5.40 | 6.75 | 8.10 | 10.80 |
| | M | | 2.15 | 3.22 | 4.29 | 5.37 | 6.44 | 8.59 |
| | L | | 1.51 | 2.27 | 3.02 | 3.78 | 4.54 | 6.05 |
| Power Input | W | | 30 | 38 | 45 | 50 | 90 | 100 |
| Noise Level | dB(A) | | 39 | 41 | 42 | 45 | 46 | 47 |
| Water Flow | kg/h | | 310 | 460 | 620 | 770 | 930 | 1240 |
| Water Resistance | kPa | | 12 | 14 | 17 | 18 | 22.5 | 23.5 |
| Fan Type | | | Cross Flow Fan Blower | | | | | |
| Motor | Type | | Cross Flow Fan Motor | | | | | |
| | Insulation Class | | Class B | | | | | |
| | Power Supply (V/Ph/Hz) | | 220~230V/1Ph/50 or 60Hz | | | | | |
| Coil | Type | | Seamless copper mechanically expanded into aluminum fins | | | | | |
| | Rows | | 2 | | | | | |
| | Max. Working Pressure | | 1.6 MPa | | | | | |
| Inlet/Outlet Water Pipe | | | ZG1/2" | | | | | |
| Condensate Water Pipe | | | Φ16 | | | | | |
| Net Dimension | W/D/H mm | | 850×300×198 | | 970×315×235 | | 1100×330×235 | |
| Net Weight | W/D/H mm | | 11 | | 15 | | 20 | |
| Gross Weight | W/D/H mm | | 13 | | 17.5 | | 23 | |

Note:

1. **Testing condition:**

Cooling: entering air temp 27°C DB/19.5°C WB; entering water temp 7°C, leaving water temp 12°C; Fan Speed High Heating: entering air temp 21°C; entering water temp 60°C, Fan Speed High, Same Water Flow as in cooling condition

2. Sound pressure level are measured in acoustic room, position of the measure point is 1m in the front and 1m below the vertical center line of the unit.

2.5 Controller outlook and operation instruction

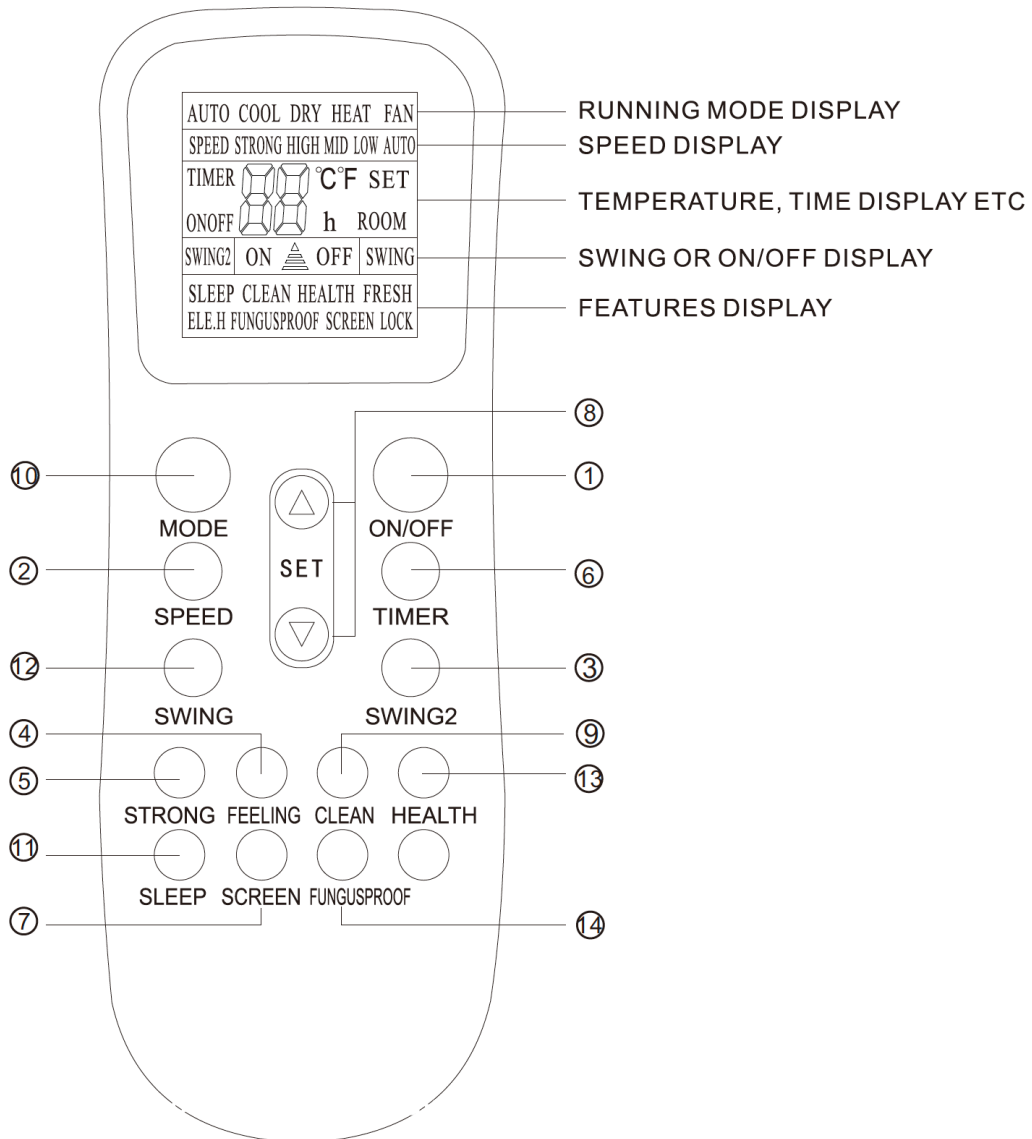

Note: The picture is general remote controller, contains almost all of the function buttons. They may be slightly different from material object (depend on model).

2.5.1 【ON/OFF】 button

You can start the fan coil by pressing this button and stop its operation by pressing it again.

2.5.2 【SPEED】 button

You can select fan speed from "Low", "Mid", "High", "Auto".

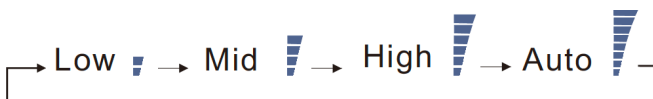

2.5.3 【SWING2】 button

Press this button, the vertical wind direction vanes can rotate automatically, when you have the desired horizontal wind direction, press it again, the vertical wind direction vanes will be stopped at the situation of your choice.

2.5.4 【FEELING】 button

When it displays “FEELING” button:

Press this button can be used to set the feeling function. The LCD shows the actual room temperature when the function set and it shows the setting temperature when the function cancelled. This function is invalid when the appliance at the Fan mode.

2.5.5 【STRONG】 button

Only under the state of cooling or heating mode, press this button, the fan speed is adjusted to strong automatically and the LCD displays “high fan”, the “strong” function is started to reach the highest cooling or heating.

2.5.6 【TIMER】 button

This button is used to set the Timing On or the Timing Off function.

2.5.7 【SCREEN】 button

You can let the LCD display work or not by pressing this button.

2.5.8 【△】 or 【▽】 button

Press the “△” or “▽” button, you can set the temperature range from 16°C to 32°C, Display will change when you touch the button.

2.5.9 【CLEAN】 button

When remote controller is at the off state, press “clean” button, the wind guiding bars turn to initial positions for cooling, the A/C runs “clean” function with max duration 35mins. The purpose of this function is to clean dust on evaporator and dry the inside water of evaporator and to prevent the evaporator going moldy due to water deposition and boasting strange smell.

2.5.10 【MODE】 button

This enables you to select different operation mode. After each pressing, the operation mode will be changed.

It shows in the following display.



Note: The cooling-only unit doesn't have heat mode.

2.5.11 【SLEEP】 button

Press SLEEP button, then display screen shows " SLEEP" , the sleeping function of the air conditioner is activated.

2.5.12 【SWING】 button

Press this button, the horizontal wind direction vanes can swing automatically, when you have the desired vertical wind direction, press it again, the horizontal wind direction vanes will be stopped at the situation of your choice.

2.5.13 【HEALTH】 button

Press this button, you can turn on or off the health function.

2.5.14 【FUNGUSPROOF】 button

This A/C has special dry and anti-mold function which has “yes” or “no” two selections. This function is controlled by the remote controller under cooling, dry and auto (cooling and dry) modes, the horizontal wind guiding bars are at the initial position for cooling. The A/C runs under heating mode (the cooling only A/C only runs under fan mode), the internal fan runs for three minutes with

weak wind before stop. The purpose of this function is to dry the inside of the evaporator and to prevent the evaporator from going moldy due to water disposition and thus dispersing strange smell.

Note:

2.5.14.1 This function has not been set in the factory. You may freely set and cancel this function. The setting method is: under “off” status of the A/C and the remote controller, point the remote controller toward the A/C and continuously press “FUNGUSPROOF” pushbutton for one time, the buzzer keep beeping five times again after five times beep, indicating that this function is ready. In case this function has been set, unless the whole A/C is powered off or the function is manually cancelled, the A/C then has this function as default.

2.5.14.2 To cancel the function: 1. Power off the whole A/C. 2. Under “off” status of the A/C and the remote controller, point the remote controller toward the A/C and continuously press “FUNGUSPROOF” pushbutton for one time, the buzzer keep beeping three times again after five times beep, indicating that this function has been cancelled.

2.5.14.3 When this function is on, it is suggested not to restart the A/C before it is completely stop. This function will not run in case of time stop or sleep stop.

2.6 Usage

2.6.1 Automatic operation mode

1. Press the ON/OFF button, the fan coil starts to operate.
2. Press the MODE button, select the automatic operation mode.
3. Press the SPEED button, you can select fan speed. You can select fan speed from LOW, MID, HIGH and AUTO.
4. Press ON/OFF button again, the fan coil stops.

2.6.2 Cooling/Heating operation mode (cold wind type has no heating function)

1. Press the ON/OFF button, the fan coil starts to operate.
2. Press the MODE button, select the Cooling or Heating operation mode.
3. Press the “ \triangle ” or “ ∇ ” button, set the temp., the temp. can be set at 1C difference range from 16-32C.
4. Press the SPEED button, you can select fan speed. You can select fan speed from LOW, MID, HIGH and AUTO.

2.6.3 Fan operation mode

1. Press the ON/OFF button, the fan coil starts to operate.
2. Press the MODE button, select the automatic operation mode.
3. Press the SPEED button, you can select fan speed. You can select fan speed from LOW, MID and HIGH.
4. Press ON/OFF button again, the fan coil stops.

2.6.3 Drying operation mode

1. Press the ON/OFF button, the fan coil starts to operate.
2. Press the MODE button, select the Cooling or Heating operation mode.
3. Press the “ \triangle ” or “ ∇ ” button, set the temp., the temp. can be set at 1C difference range from 16-32C.
4. Press the SPEED button, you can select fan speed. You can select fan speed from LOW, MID, HIGH and AUTO.

5. Press the ON/OFF button again, the fan coil stops.

2.6.4 Timer button mode

2.6.4.1 Clock function

Clock setting during using period the method just like below:

1. Open the lid of the remote controller, then press Timer/Clock button, the clock function is activated.
2. Press the “ \triangle ” or “ ∇ ” button to set the clock time, the time is 12-hour system with a.m. & p.m.
3. Press the TIMER button again to confirm the clock time.

2.6.4.2 Timing ON function

Time ON function must be set when the fan coil is off. The method is as follows:

1. Press TIMER button, the letter “ON” will be displayed and flicker.
2. Press the “ \triangle ” or “ ∇ ” button to set the time, the time is 12-hour system with a.m. & p.m.
3. Press the TIMER button again to confirm the clock time.
4. Press other button to select the operation condition. (Including mode, temperature, swing, fan speed, etc.)

Note: When the clock or timing on setting is the same as the setting time, the fan coil will automatically close or operate.

2.6.5 Sleep operation mode

1. Press the ON/OFF button, the fan coil starts to operate.
2. Press the MODE button, select the Cooling or Heating operation mode.
3. Open the lid of the wired controller, press the SLEEP button, the display will shows the sleeping function is activated.
4. Press SLEEP button again, the sleeping function will be cancelled. Then the fan coil will keep its setting to operate.
5. Press ON/OFF button, the fan coil stops.

When the sleep function starts, it will operate like:

1. Cooling mode:



2. Heating mode:



3. The sleep mode will last for 7 hours, and then stop automatically.

3. Installation

3.1 Checking and acceptance

Each fan coil is packaged in corrugated cartons to avoid damages during transportation, handling and site placement. To make sure no damages occurred due to transportation, please follow below steps to check upon receiving the equipment:

- a) Before acceptance, please check if each unit shows any abnormal facts, if carton edges and corners are in good conditions and if there are obvious carton damages;
- b) For any obvious carton damages, please immediately unpack to inspect the unit itself. If the unit is indeed damaged, please indicate on the receipt and refuse to accept. Please also check accessories;
- c) Check hidden damages of the unit;
- d) If any hidden damage is found, do not move the unit on the site. The receiver has the obligation to evidence such damage does not occur after delivery. Meanwhile, please stop unloading and take photos for reference;
- e) If damages are found, please notify the carrier, and request the carrier and the receiver to conduct a joint inspection;
- f) Do not repair it yourself before inspection and confirmation by the carrier representative has been made;
- g) After confirmation of damages, please contact related persons for replacement.

3.2 Transport

DAMAGE TO UNIT AND PERSONAL INJURY!

- Use protective gloves to avoid injury due to sharp edges.
- Ensure that at least two people carry the fan coil to avoid injury.
- In case of deliveries on pallets, use only lifting and transport vehicles with sufficient carrying capacity.
- Secure the load during transit to prevent it from tipping or falling.

3.3 Prepare for Installation

DANGER FROM ELECTRICAL CURRENT!

- Ensure that the intended drilling area is free from electrical cables or pipes before drilling.

PERSONAL INJURY!

- Injury may be caused by falling parts and sharp edges!
- Wear a helmet, safety boots and protective gloves when installing the unit. Ceiling installations should always be performed by two people.

NOTE!

- **You must ensure that no mechanical deformations or twisting occurs during installation of all models in all installation locations.**

3.4 Unit Installation

3.4.1 Valve connection

The units are supplied without valves, In case of installation with valves by others, the installation of the water inlet and outlet depends on the location of the medium/water connection and/or the used valves.

Below showed Pic. indicate the connection of a 2-way valve and 3-way valve to the units.

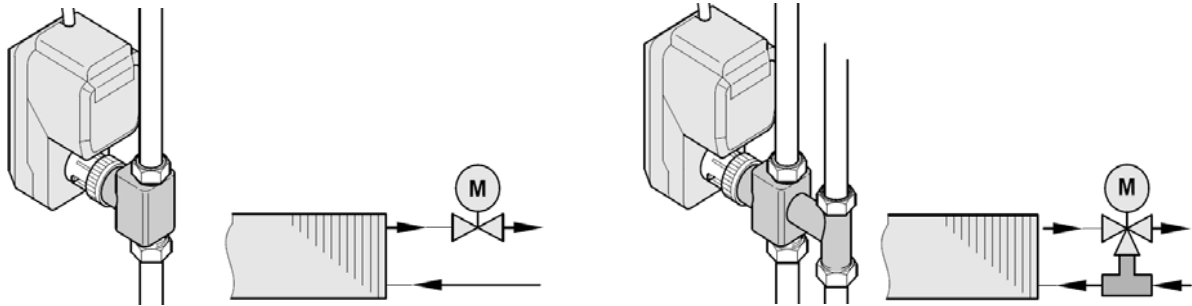

NOTE!

- Water inlet in lower position while water outlet in higher position, refer to connection fittings indication stuck on side of unit.
- Flexible connection must be used and connected to water inlet/outlet fittings.
- Stop valves must be installed in water inlet/outlet pipeline.
- Air discharge valve must be installed in the highest position of the water system.
- Water discharge valve must be installed in the lowest position of the water system.

3.5 Piping connection

! DANGER OF SCALDING BY ESCAPING HEATING MEDIUM!

Before the on-site piping and the fan coil hydraulic connection is set up, the heating/cooling water should be isolated and secured against being opened unintentionally.

NOTE!

- All on-site pipes by others for the cooling medium must be insulated against condensate formation. If the pipes are run close to the lateral condensate tray, they should be isolated above the lateral condensate tray by others on-site.
- When all connections have been completed, all screw connections should be tightened and checked that they are free of mechanical stress.
- In order to ensure cleaning or disassembly of the heat exchanger according to the hygiene guidelines appropriate measures shall be taken so that medium connections at the heat exchanger could be disconnected at anytime.

Please refer to below illustrative piping connection pic. for piping work.

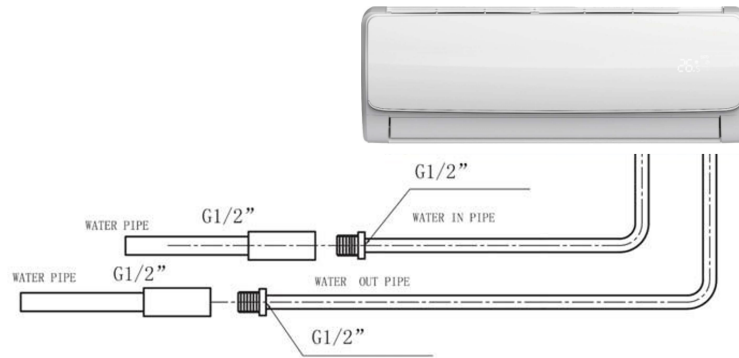

3.6 Condensate water pipe connection

In order for the condensate to be drained off properly, the condensate drain by others must be connected to the lateral condensate tray.

- Run the condensate drain at an angle/slope.
- When connecting the condensate drain to the wastewater system, observe the wastewater regulations (stench trap).

NOTE!

- **Condensate drains must always be positioned at a sufficiently steep angle! (Recommend 1:100). When running pressure less pipes or draining outdoors, no stenchtrap is required.**
- **The onsite condensate drain line is to be connected to the connector of the condensate tray in a stress-free way.**
- **To avoid dew formation during cooling, chilled water pipe and condensate pipe must be thermally insulated with careful treatment at insulation ends.**

NOTE!

- **Before carry out any wiring connection, always refer to the wiring diagram sticked on the back cover of the electric sheet box for the right information.**

3.7 Electric Wiring

DANGER FROM ELECTRICAL CURRENT!

- The electricity shall be disconnected before make any installation work.
- The electrical installation of the air treatment unit must only be carried out by qualified electricians in observance of this operation manual.
- The electrical connection of fan coil units must be performed in accordance with the valid connection diagrams. The connection diagram is located on the side of the sheet electric control box.
- The earth point provided on the unit shall be connected to the grounding system of the building.
- All electric connections shall comply with local electric regulations.
- The connection diagrams do not contain any protective measures. During connection, the standards and regulations currently in force must be observed and cleared with the local electricity company.

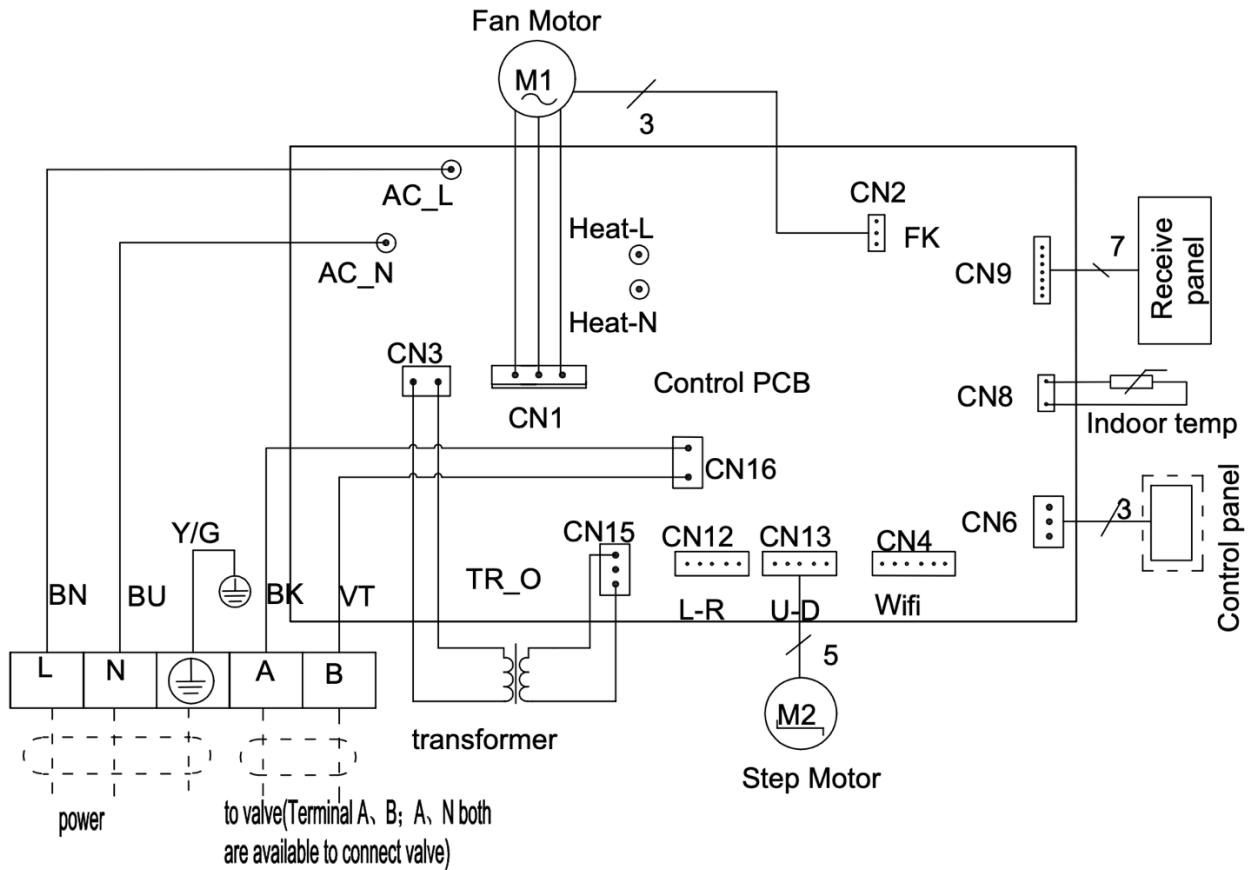

DAMAGE TO THE UNIT!

- Wrong wiring connection may cause permanent damage to fan motors
- Make wiring according to the indication on the wiring diagram stuck on the back of elec. box.

NOTE!

- Please make the correct wiring of motorized 2-way or 3-way valve and thermostats in according to its installation instructions and make correct linkage between the units.

4. Commissioning

ELECTRICAL HAZARD!

Before carrying out any work on the unit, power the unit down to avoid injury from electrical current. Check that the unit is isolated and ensure that the appropriate point of the unit for the on-site power supply is secured against being switched back on.

DANGER OF SCALDING!

Before performing work on the valves or the inlet or outlet pipes, seal off the heating or cooling medium inlet to prevent scalding. Do not commence work before the heating medium has cooled down.

DANGER OF ROTATING UNIT PARTS!

Rotating fan wheels can cause injury! Before performing any work on the unit, ensure that it is powered down. Ensure that the appropriate point of the unit for the on-site power supply is secured against being switched back on.

4.1 Requirements for commissioning

After installation, the installers shall re-inspect and confirm the following items have been made. This manual has been carefully read through. Operators are generally familiar with the unit and can operate it.

- The fan coil is electrically isolated.
- The entire fan coil system has been installed both mechanically and electrically.
- All medium/water pipes have been rinsed and are free from residues and foreign objects.
- The system is properly pressurized (Recommended test pressure 2.4Mpa and more than 10min) and then filled with clean medium/water.
- Check that the fan coil is properly fixed and mounted (on the wall, ceiling or on the floor).
- Manually check if valves, actuators thermostats are secured according to its operation manual.
- Tighten all medium/water screw connections.
- Check all electric connections using current wiring diagrams and check terminal strip screws for correct tight seat.

NOTE!

Before commissioning, ensure that

- the unit discharge (heat exchanger),
- the filter medium are clean.

If necessary, these components may have to be cleaned or the filter medium changed.

NOTE!

- For first water filling, the fan coil pipeline may retain some air, which will be finally entrapped at top of the water system. A manual discharge valve is provided at the water outlet joint of the water system. When abnormal noise is heard due to residual air in the water system or coil, turn the discharge valve knob to release the air. If the knob is too

tight, you may use a pair of pinchers to turn it anticlockwise until water flows out of the valve steadily, and then tighten the knob again.

4.2 Startup

The fan coil usually is controlled by a infrared controller, pls refer to controller operation instruction to operate the units.

NOTE!

- **After the commissioning, in case of non-use in winter season, water inside the unit shall be drained to avoid pipe cracks due to ice formulation.**

5. Maintenance and Trouble shooting

ELECTRICAL HAZARD!

Before carrying out any work on the unit, power the unit down to avoid injury from electrical current. Check that the unit is isolated and ensure that the appropriate point of the unit for the on-site power supply is secured against being switched back on.

DANGER OF SCALDING!

Before performing work on the valves or the inlet or outlet pipes, seal off the heating or cooling medium inlet to prevent scalding. Do not commence work before the heating medium has cooled down.

DANGER OF ROTATING UNIT PARTS!

Rotating fan wheels can cause injury! Before performing any work on the unit, ensure that it is powered down. Ensure that the appropriate point of the unit for the on-site power supply is secured against being switched back on.

5.1 Maintenance

The Wall Mounted fan coil unit is a high-quality and reliable unit. However, to guarantee the permanent functioning and performance of the unit, regular maintenance and inspection by technical experts is necessary.

NOTE!

- **Maintenance may only be performed by trained technical personnel in observance of this operation manual and current regulations.**
- **The manufacturer's warranty will be invalidated if unit damage is attributed to the failure to perform regular maintenance and inspections.**
- **The valid warranty prescribes to maintain a written maintenance report according to the following table.**

5.2 Checklist of Periodic Maintenance

The following is a suggested maintenance plan.

Monthly Check

If the drainage pipe is clean and if condensate can flow to the drain pipe freely.
If the filter is clean to guarantee the maximum cooling/heating performance.

Yearly Check

- a) Check if the unit casing is corroded. Clean and repair it if necessary;
- b) Check if the fan blades and volute are damaged. Manually turn the blades to make sure it rotates freely without obstacles;
- c) Check if coil fins are too dirty or damaged;
- d) Clean and tighten all electric wirings;
- e) Drain chilled water of all the system to make descaling and water replacement

NOTE!

- **Untreated water may cause unit scaling, corrosion and deterioration. System testing and maintenance shall be guided by water treatment experts. The manufactory shall not be held liable for any losses due to poor water quality.**
- **Due to limitation of support weight and dimensions, this job shall be collaborated by two installers to ensure safety.**
- **During off period in winter, water inside the unit shall be drained to avoid pipe cracks due to ice formulation.**

5.3 Filter and Coil Cleaning

Blocked or contaminated filter and coil may decrease cooling capacity. It is recommended to clean them every 3 month in the following steps.

1. Disconnect the power and motor wiring to stop rotation of fan blades;
2. Take out the filter and wash to clean it.
3. Clean the coil by brush;
4. Connect the power and water supply. Make trial operation to see the effect.

5.4 Troubleshooting

Deviations from normal operating states of the fan coil units are evidence of malfunctions that must be investigated by maintenance personnel.

The following table should serve as a starting point for maintenance personnel regarding possible causes of trouble and their correction.

Fan Coil Unit – Wall Mounted Type

| Fault | Possible causes | Remedy | M | |
|--|---|---|---|---|
| Fan does not work | Unit not switched on | Switch on unit | | |
| | No electrical voltage | Check fuse/power supply | * | |
| | Electrical cables not connected | Connect electrical cables | * | |
| | Unit fuses defective | Replace fuses | * | |
| Unit too noisy | Too high RPM level switched on | Set a lower RPM level | | |
| | Air intake blocked | Clear discharge/air intake of obstructions or kinks | | |
| | Noisy fan bearings | Replace the faulty fan | * | |
| | Filter is dirty | Clean/replace the filter | | |
| Unit does not cool(heat) or cool(heat) insufficiently | Fan not switched on | Switch on the fan | | |
| | Air volume flow of the unit too low | Select a higher RPM level | | |
| | Air intake or discharge areas blocked | Unobstructed or clean airways | | |
| | Fan blocked/faulty | Check fan, replace if necessary | * | |
| | Filter is dirty | Clean/replace the filter | | |
| | Water flow rate too low | Check pump performance, Check pipe run balance and adjust using calculated pressure loss | * | |
| | Cooling medium is not cold | Switch on chilled water set, Switch on the circulating pump, Bleed the system | | |
| | Heating medium is not hot | Switch on the heating system boiler, Switch on the circulating pump, Bleed the system | | |
| Water leakage in unit area | Side wall-mounted/ceiling-mounted condensate tray drain blocked | Clean condensate pipe and check for sufficient gradient, then clean and fill the siphon if necessary | * | |
| | Chilled water pipes not correctly insulated | Insulate the chilled water pipes | * | |
| | Unit not positioned horizontally | Align the unit and position it horizontally | * | |
| | Heat exchanger or hydraulic connections leaking | Check the heat exchanger, bleeding and valve connections for leaks | | |
| | | If necessary, retighten connections, clean screw insert or reseal the connections | | |
| | | On valves, check the screw connections for ease of movement, clean sealing surfaces and replace seal if necessary | | * |
| | | Check the soldered joints between the collector and heat exchanger tubes and on the heat exchanger deflection bends for leaks; if leaking, replace the heat exchanger | | * |

*Items marked with * can only be performed by technical person only.

For Better Air!



Respect the environment!

For a correct disposal, the different materials must be divided and collected according to the regulations in force.